

COMMONWEALTH OF AUSTRALIA
SPACE LICENSING AND SAFETY OFFICE

FLIGHT SAFETY CODE

Second Edition

Department of Industry, Tourism and Resources
1 July 2002

ISBN - 0 642 72301X
ITR - 2002/064

Table of Contents

Section	Page No
1 Introduction	3
1.1 Overview	3
1.2 Principles and Philosophies	3
1.3 Responsibility for Administration	4
1.4 Flight Readiness	5
1.5 Risk Identification, Analysis and Control	6
1.6 Flight Safety Systems	6
2. Definitions	7
3. Launch Safety Standards	9
3.1 Third Party Casualty Safety Standards	9
3.2 Asset Safety Standards	9
3.3 Unproven Launch Vehicle Safety Standards	10
3.4 New Space Licence Safety Standards	10
3.5 Controlled Area Safety Standards	10
3.6 Flight Safety Systems Standards	11
4. Risk Hazard Analysis Methodology	11
4.1 Introduction	11
4.2 Casualty Expectation	12
4.3 Mutually Exclusive Events	15
4.4 Computing Probability of Failure	17
4.5 Computing Probability of Impact and Casualty Expectation for Different Flight Phases	24
4.6 Establishing a Debris Catalogue	29
4.7 Computing Casualty Area	30
4.8 Population Density	33
4.9 Launch Safety Standards	34
5. Contact Details	36
Appendix 1 Preferred Methodology for Computing Casualty Area	37
Appendix 2 Risk Analysis Examples	50

1. INTRODUCTION

1.1 OVERVIEW

1.1.1 The *Space Activities Act 1998* provides legal authority for the Commonwealth Government of Australia to license certain space launch and re-entry activities from Australia and launches, from overseas sites, of payloads in which Australian nationals have an ownership interest. The Act establishes a licensing regime to regulate such activities and, in doing this, implements Australia's obligations under United Nations Conventions and bilateral agreements with other countries, ensures the protection of people and property, and provides a transparent, stable and predictable operating environment for those wishing to participate in space launch activities.

1.1.2 The Act is supported by the *Space Activities Regulations 2001*, which provide further detail about the licensing regime and material to be prepared in support of an application for a licence, permit or certificate under the Act. The Act is also underpinned by several documents addressing the safety of proposed launch activities from Australia and the determination of the minimum amounts for which insurance must be taken out in respect of potential loss or damage.

1.1.3 This Flight Safety Code sets out the requirements of applicants to demonstrate that their proposed launch activities will be safe and effective. As such, it represents a critical element of evidence to be used to satisfy the Minister that the probability of the launch or launches, and any connected return, causing harm to public health or public safety, or causing substantial damage to property, is sufficiently low. The Code derives its legal authority from the *Space Activities Regulations 2001*. All individuals, organisations and companies seeking approval to conduct space launch activities in Australia must comply with the Code.

1.1.4 Specifically, this Code sets out the safety standards that must be achieved in respect of the risks posed to third parties by space launches and the methodology to be used to calculate the risk. The casualty safety standards are aimed at ensuring that the risks to public health and safety are low. The asset safety standards are aimed at ensuring the potentially catastrophic risks associated with designated assets are identified and are low. The standards also provide for restrictions to be applied to unproven vehicles overflying populated areas and for restrictions on new launch licensees flying in the vicinity of petroleum facilities. The standards to be observed in respect of drop zones and landing sites are also set out.

1.2 PRINCIPLES AND PHILOSOPHIES

1.2.1 Safety of the public, property and major national assets underpins the safety regime. The safety regime is based on a 'safety case' approach which places responsibility for the ongoing management of safety on the launch operator. A launch proponent will present a safety case to the regulator to demonstrate that the risks associated with the operation of the launch facility, the launch vehicle and the proposed flight paths are as low as reasonably practicable.

1.2.2 The role of the regulator is to assess, accept and audit the adequacy of the safety case presented by the launch proponent. The regulator will also provide guidance to applicants in the preparation of the safety case.

1.2.3 The safety case in respect of the proposed site, launch vehicle and flight paths will need to be demonstrated before a space licence will be issued under the *Space Activities Act 1998*. This case should draw on all material provided with an application for a space licence, but in particular the Program Management Plans, completion of the Risk Hazard Analysis (including assumptions underpinning that analysis) and demonstrated capacity to meet the Launch Safety Standards. Individual launches from a licensed facility will need to satisfy the safety standards accepted under the licensee's safety case and, in so doing, to at least satisfy the safety standards for every launch.

1.2.4 The safety regime acknowledges public expectations that the risk of death or serious injury from commercial space activities should not exceed that from comparable industries. The Launch Safety Standards are the mechanism by which the community and certain assets with catastrophic potential are protected from any potential impact from space launch activities.

1.2.5 People and community facilities are protected by the third party safety standards. These limit the risk any individual may face as a result of a launch, the risk any individual may face as a result of regular operation of the launch facility, and the collective risk to the public. Collective risk limits the average number of casualties per launch and ensures that the number of people exposed to risk is limited. The launch will not proceed if these standards are not met.

1.2.6 Property that is regularly occupied by people or is in a significantly populated area is protected by the third party safety standards discussed above. Facilities that are remote from a significantly populated area and which are in need of special protection because of their catastrophic potential may be afforded that protection through the asset safety standards.

1.3 RESPONSIBILITY FOR ADMINISTRATION

1.3.1 Under the *Space Activities Act 1998*, the Minister has authority to issue licences and permits giving due regard to public health, safety of life and property, Australia's national security and foreign policy obligations, the impact on the environment, and the technical and corporate competency of the applicant. A body within the Department of Industry, Tourism and Resources - the Space Licensing and Safety Office (SLASO) - has responsibility for assessing all applications for instruments under the Act, as well as all material provided in support of such applications. Some of the powers of the Minister to issue licenses and permits may be delegated to the Director of the SLASO.

1.3.2 In particular, the SLASO will review and assess applications for licenses and permits, and provide recommendations on granting licenses or permits. The SLASO will also review and approve, for the purposes of granting a licence, all safety-critical designs, such as autonomous flight termination systems, system test and documentation for the overall airborne flight safety system, and has final authority for mitigating the risk to the public, to properties and to the launch area, including pre-launch and launch operations. Operational and engineering design for flight safety systems, ground force systems, scientific analysis and safety risk criteria for all launches will be rigorously assessed by the SLASO.

1.3.3 The safety case presented in accordance with the Launch Safety Standards and Risk Hazard Analysis, set out in this document, will be subject to rigorous scrutiny by the

SLASO, including all data and assumptions underpinning the calculations. The final authority and responsibility to approve a launch rests with the Minister or his delegate. The Launch Safety Officer, located on the site of the launch, has powers to ensure compliance with a licence or permit, inspect the facility and any equipment contained therein, and to give directions to stop the launch or destroy the launch vehicle.

1.4 FLIGHT READINESS

1.4.1 The *Space Activities Act 1998* and *Space Activities Regulations 2001* set out all requirements of applicants, upon which the process to approve launch activities will be based. This process includes a number of steps that are pre-requisite to an approval to launch being granted, and involves assembly, testing and check-out, and verification that all vehicle systems are operating as required and in proper configuration for launch. Material to facilitate this process will be drawn from documentation submitted about the type of launch vehicle and the Program Management Plans. In applying for a space licence, the applicant will include the results of all testing and checkout of the launch vehicle in their material on the type of launch vehicle for review by SLASO. The applicant will also identify all hazardous ground operations and procedures for review, as set out in the Emergency Plan. The SLASO will monitor compliance with such operations and procedures.

1.4.2 The SLASO will engage in a process to assess the readiness of arrangement for flight, drawing on material provided in applications for both a space licence and launch permit. In this context, all anomalies and failures of systems will be identified and corrective actions assessed to ensure compliance with established requirements. Any anomaly or corrective action that degrades or compromises public safety will be scrutinized and the SLASO may seek further information on these matters [under authority of Section 60 of the Act]. The applicant will also demonstrate that risk levels are within the established standards identified in this Flight Safety Code by conducting a risk assessment in accordance with the methodologies and processes set out in this Code. Should any of the assumptions or data on which the assessment was based change prior to the launch, such changes should be provided to the SLASO, along with confirmation that the Launch Safety Standards are met.

1.4.3 Based on information provided in the Program Management Plan for the launch or return, the SLASO will review final readiness for the launch not more than two days prior to that launch or return. The purpose of the review is to assess whether:

1. system and personnel readiness problems are identified and are associated with a plan to resolve them;
2. all systems needed for flight have been verified and are ready; and
3. each participant is aware of his or her role on the day of flight.

1.4.4 Where arrangements or assumptions have changed and compliance with the Launch Safety Standards is in doubt, the Launch Permit will be suspended or revoked, as appropriate. The Launch Safety Officer has authority under the *Space Activities Act 1998* to oversee all pre-launch activities.

1.5 RISK IDENTIFICATION, ANALYSIS AND CONTROL

1.5.1 Comprehensive identification of hazards is a major contributor to safety. As noted in the Report of the Longford Royal Commission, 1999, “once the [hazards] have been identified, the battle is more than half won”. Hazards of particular interest in this Flight Safety Code are those to the public and to property not owned by the applicant which arise from the launch or return of a space object. In the case of launches, the period to which hazard identification, analysis and control analysis applies will be the period from the commencement of the launch and concluding 30 days after the commencement of the launch. In respect of returns, the period will be the period beginning when the relevant re-entry maneuver has commenced and ending when the object has come to rest on Earth. Risk criteria will be more conservative when the consequence of a single event is significant, that is it can result in many casualties or in very high financial loss.

1.5.2 Persons seeking to conduct authorised space activity in Australia are to comprehensively identify and explicitly document the hazards posed to the public and to property not owned by the applicant by the flight of the space object. As a guide, applicants are referred to *Hazard Analysis of Commercial Space Transportation*, Office of Commercial Space Transportation, Licensing and Safety Division, U.S. Department of Transport, May 1988, OCST-RD-RES01-88. Volume II identifies a number of hazards for consideration.

1.5.3 Hazard identification will be scrutinised by the SLASO. An occurrence during a launch or return of a kind that is not explicitly identified by the applicant and disclosed to the SLASO may be regarded as an occurrence that could affect the safety of the operation of the space object for the purposes of the definition of an incident in Section 86 of the Act.

1.5.4 From a public safety standpoint, risks from impacting inert and exploding debris and from toxic gases are the primary considerations. Hazards shall be analysed and risks quantified in accordance with the Risk Hazard Analysis Methodology set out in Section 4 of this Code, or an alternative methodology approved according to the Regulations. All assumptions and data underpinning the results of the analysis must be documented in the Flight Safety Plan and provided to the SLASO as part of the application for a launch permit. Such assumptions and data will be closely scrutinised by the SLASO.

1.5.5 The risks to the public posed by a space activity are to be controlled to a level that is as low as reasonably practicable. A launch will not be approved unless the risk hazard analysis provides satisfactory evidence that the launch, if carried out according to plan, will satisfy the Launch Safety Standards set out in this Flight Safety Code.

1.6 FLIGHT SAFETY SYSTEMS

1.7.1 A Flight Safety System (FSS) is a risk mitigation method that detects an aberration in launch vehicle health or positioning and terminates flight in response. The system, manually or autonomously activated, is required as a means of controlling the vehicle to minimize the risk to life and property. With the exception of certain sub-orbital missions, evidence is required that a FSS has been installed on all vehicles that will be licensed under the *Space Activities Act 1998*. The system is to be operable throughout the entire powered flight phase and re-entry phase of a mission, must be at least single fault tolerant, and be capable of terminating the flight when nominal flight conditions have been transgressed by a predetermined margin. The system may be destructive resulting in the intentional breakup of a vehicle or nondestructive such as engine thrust termination enabling vehicle landing or safe abort. The system may be manually operated or fully autonomous. If the system is fully autonomous, it must incorporate at least one level of

redundancy with a reliability requirement for successful operation of 0.999. If the FSS is to be activated manually, it must operate with a reliability of 0.998 with 95% confidence. On any manually operated FSS, evidence is required that tracking and monitoring of the flight will take place. The technology to be adopted will not be stipulated, however evidence is required to demonstrate effectiveness and reliability.

1.7.2 Evidence is required to demonstrate that all flight-safety-critical systems/components are at least single fault tolerant; that is they will incorporate one level of redundancy. This aims to prevent potential single point failures.

1.7.3 Evidence is required to demonstrate that reusable launch vehicles incorporate a positive fail-safe reentry system to ensure that reentry flight occurs under the conditions necessary to ensure that the risks to public safety do not exceed prescribed levels. The reentry command may be autonomous with the uplinking of current meteorological data and need not include a person in the loop. The technology to be adopted will not be stipulated, however evidence is required to demonstrate effectiveness and reliability.

2. DEFINITIONS

2.1 This Flight Safety Code uses a number of terms which are unique to the space launch industry and which have meanings of particular relevance to this Code. Terminology is thus defined as set out below and should be read in context of this Code. These definitions do not override those set out in the *Space Activities Act 1998*.

asset risk: the risk to a Designated Asset or Protected Asset.

casualty area: an area around a debris impact point in which a person who is present will become a casualty in the event of that debris impact.

casualty expectation: the average number of casualties that can occur as a result of an event if the event were to be repeated thousands of times.

catastrophic chain of events: assessed according to the criteria set out in the "Administrative Arrangements for the Classification of Assets for Space Launch Activities".

collective risk: the total casualty expectation from a launch or return.

controlled area: a drop zone area or landing site area.

debris: any material that poses a hazard if it falls to ground as a result of the intended or unintended break up of a space object.

debris footprint: the impact distribution for debris predicted to result from a particular event.

Designated Asset: an asset designated by the Minister for Industry, Tourism and Resources and set out in the List of Designated and Protected Assets.

dispersion footprint: an area in which returned space objects, scheduled debris, or debris returns to land, defined by an impact probability isopleth or a standard deviation boundary.

drop zone: an area for the impact of scheduled debris.

drop zone area: a four standard deviation dispersion footprint around the nominal impact point of scheduled debris.

impact probability: the probability of a space object, or debris, impacting on a location, area, facility or person.

impact probability isopleth: a line on a map connecting places of equal impact probability.

individual risk: the risk to a single person exposed to a launch or return, or a series of launches or returns.

hazard: a potential source of casualty or loss.

landing site: an area for the planned return of a space object including a re-usable launch vehicle.

landing site area: a four standard deviation area around the nominal impact point for the return of a space object or re-usable launch vehicle.

nominal impact point: planned or intended impact point of scheduled debris or for the return of a space object.

population centre: a person, group of persons or area of population, considered as a single entity for the purpose of the methodology of risk determination.

Protected Asset: a Designated Asset defined as protected by the Minister for Industry, Tourism and Resources and set out in the List of Designated and Protected Assets.

risk isopleth: a line on a map connecting places of equal risk.

scheduled debris: planned or intended debris from a successful launch.

significantly populated area: a city, town or settlement, but not an isolated house or homestead.

standard person: a hypothetical object of cylindrical shape with a circular base of radius 0.3 metres and linear height of 2 metres.

successful launch: for the purposes of flight safety, a launch which does not suffer a malfunction that could pose a hazard to the public.

trigger debris: debris capable of triggering a catastrophic chain of events on a Designated Asset (see Section 3.2).

unproven vehicle: a launch vehicle that has not achieved five consecutive missions without a failure that could pose a hazard to life and/or property.

3. LAUNCH SAFETY STANDARDS

The party responsible for the launch or return of a space object is required to meet the following launch safety standards for risks posed to third parties.

3.1 THIRD PARTY CASUALTY SAFETY STANDARD

3.1.1 The maximum third party collective risk (the sum of casualty risks to all individuals in the general public) on a per launch basis:

10^{-4} per launch.

3.1.2 The maximum third party individual risk on a per launch basis:

10^{-7} per launch

3.1.3 The maximum third party individual casualty risk on a per year basis:

10^{-6} per year

3.2 ASSET SAFETY STANDARDS

Designated Asset

3.2.1 The maximum probability of debris impact on a Designated Asset on a per launch basis:

10^{-5} per launch

3.2.2 The maximum probability of debris impact on a Designated Asset on a per year basis:

10^{-4} per year

3.2.3 The maximum probability of *trigger debris* impact on a Designated Asset on a per launch basis:

10^{-7} per launch

3.2.4 The maximum probability of *trigger debris* impact on a Designated Asset on a per year basis:

10^{-6} per year

Trigger Debris

3.2.5 Trigger debris is space debris of a particular shape, weight, velocity or explosive potential that is capable of triggering a catastrophic chain of events on a Designated Asset or Protected Asset. Trigger debris is determined on the basis of expert engineering analysis commissioned by the launch proponent and agreed by the owners of the space launch facility and the relevant asset.

3.2.6 In the event the parties do not agree within a reasonable time, the Minister will determine such debris based on expert engineering analysis (commissioned by the owner of the space launch facility) and cases put forward by the owners of the asset and launch facility. Further arrangements for the determination of trigger debris are set out in the “Administrative Arrangements for the Classification of Assets for Space Launch Activities”.

Protected Asset

3.2.7 A Protected Asset must be at least 10km outside the 10^{-7} impact probability isopleth for trigger debris on a facility of its physical dimensions, on a per launch basis.

3.3 UNPROVEN LAUNCH VEHICLE SAFETY STANDARDS

3.3.1 An unproven launch vehicle may be restricted from flying in the vicinity of significantly populated areas

3.4 NEW SPACE LICENCE SAFETY STANDARDS

3.4.1 A launch vehicle shall be restricted until it has completed three consecutive successful launches under a space licence. Designated Assets will be treated as Protected Assets until three consecutive successful launches have been completed under a space licence.

3.5 CONTROLLED AREA SAFETY STANDARDS

3.5.1 A controlled area is an area for the intended impact of returned space objects, called a landing site, or for scheduled debris, called a drop zone. A controlled area is defined as a four standard deviation dispersion footprint around the nominal impact point for the return of a space object or for scheduled debris. The probability of impact within the controlled area is 0.99967. The third party casualty and asset risk safety standards also apply in controlled areas.

Drop zones

3.5.2 A drop zone is an area for the impact of scheduled debris from a space object. Scheduled debris may include jettisoned booster rockets, rocket motor stages, payload fairings, nose cone, or other debris which is scheduled to fall to ground as a result of a successful launch.

3.5.3 To meet the per launch third party individual risk standard, the launch must not proceed if a third party individual may be within the area around the nominal impact point defined by the 10^{-7} individual risk isopleth during the time period for the drop. The launch must not proceed unless the area within the 10^{-7} individual risk isopleth is monitored and an all clear signal is given from the drop zone, unless the licensee can establish that pre-launch surveillance of the drop zone is not necessary because of adequate exclusion arrangements in the case of land drop zones, or because of sufficiently low likelihood of persons being in the drop zone area in the case of marine drop zones.

3.5.4 The launch must not proceed unless every individual within the drop zone area during the relevant period has been informed of the launch.

3.5.5 The launch must not proceed if a Designated Asset is within the drop zone area.

3.5.6 The launch must not proceed unless the party responsible for the launch is able to monitor and record the location of all drops intended to fall into a drop zone area proximate to a Designated Asset (50 kilometres from the outer boundary of the drop zone area). The location of actual drops will be published within 5 working days of completion of the launch.

Landing site

3.5.8 A landing site is an area for the planned return to the earth of a space object, including a reusable launch vehicle. To meet the per launch third party individual risk standard, the return must not proceed if a third party individual may be within the area around the nominal impact point defined by the 10^{-7} individual risk isopleth during the time period for the return.

3.5.9 The return must not proceed unless every third party individual within the landing site area during relevant period has been informed of the launch and of the nominal impact point and the nominal impact time.

3.5.10 The return must not proceed if a Designated Asset is within the landing site area.

3.5.11 The return must not proceed unless the party responsible for the return is able to monitor and record the location of all returns intended to fall into a landing site area proximate to a Designated Asset (50 kilometres from the outer boundary of the landing site area). The location of actual returns will be published within 5 working days of completion of the launch.

3.6 FLIGHT SAFETY SYSTEMS STANDARDS

A Flight Safety System (FSS) is to be installed on all vehicles to be licensed, however the SLASO may, by written notice, exempt certain sub-orbital vehicles involved in a particular launch or series of launches. The FSS is to be operable throughout the entire powered flight phase and re-entry phase of a mission, must be at least single fault tolerant, and be capable of terminating the flight when nominal flight conditions have been transgressed by a predetermined margin. If the system is fully autonomous, it must incorporate at least one level of redundancy with a reliability requirement for successful operation of 0.999. If the FSS is to be activated manually, it must operate with a reliability of 0.998 with 95% confidence. On any manually operated FSS, evidence is required that tracking and monitoring of the flight will take place.

4. RISK HAZARD ANALYSIS METHODOLOGY

4.1 Introduction

4.1.1 Risk analyses are conducted to measure the risk to the public from a potential launch or re-entry mishap and to ensure that operations that may exceed a nominated threshold are not permitted. The public includes all persons except

those participating in the launch or re-entry. The acceptable risk level adopted for commercial space missions should not exceed the risk expectations of the general public.

- 4.1.2 The hazards under consideration for launch operations in Australia are the consequences of debris striking persons either directly as inert debris or as explosive debris and as overpressure effects in the event of that explosion, and the consequences of debris striking designated assets. (Rocket launches also create toxic and distant focussing overpressure hazards. These are not usually considered in the design of a mission, but are a consideration as part of the “go – no go” decision on the day of launch. Procedures to determine if these are potential considerations are included as appendices.) The spent stages of expendable launch vehicles are to be treated as inert debris and appropriate analysis is to be conducted for their potential effects. The risk measure is generally known as Casualty Expectation (E_c) and is a calculation that expresses the collective risk (average number of casualties per launch) to the population exposed to the debris hazard. That is to say, the E_c calculation applies to the total population at risk rather than to each individual within that population as the concept of collective risk is inherent in the methodology. The average risk to an individual can be calculated by dividing the E_c figure by the number of persons in the population exposed to the hazard. This average individual risk can also be computed for specified classes of people or for people in each of various locations. A casualty is defined as a fatal or serious injury to a person.

4.2 Casualty Expectation

- 4.2.1 E_c is the average number of casualties that can occur if the proposed launch were to be repeated thousands of times. Its dimension is number of people and hence is not a probability. Mathematically the formal equation is

$$E_c = 1 \times \text{Probability (exactly 1 casualty)} + 2 \times \text{Probability (exactly 2 casualties)} \\ + 3 \times \text{Probability (exactly 3 casualties)} + \dots = \sum i \times \text{Probability (i)}$$

- 4.2.2 The above equation is generally of little use however, since the probabilities of exactly two or more casualties are usually very small compared to a single casualty, particularly due to inert debris. Later in this section, a more useful formula is introduced.
- 4.2.3 A casualty is defined as either the serious injury or death of a person exposed to the launch. In order to be reasonable about the degree of injury, it is normal to use the term "serious injury" as defined in the *Air Navigation Act 1920* that broadly states that it is sufficiently severe to require hospital care. There are two reasons for using casualty as the risk measure instead of fatality:
- 4.2.3.1 The effects of rocket launches can be due to direct impact of debris, overpressure from explosions, and toxic gases from burning propellants. The ratio of casualties to fatalities is quite different in each of these cases. Direct impact by non-exploding debris can cause both injuries and fatalities. There may be no fatalities from toxic gases while there are hundreds of casualties. With overpressures, direct impingement on people close to the source can cause both injuries and fatalities while broken glass from distant focusing of overpressure can produce many injuries but few or no fatalities. Thus, if fatality is the only measure, consequences from toxic gas and distant breakage of glass can be overlooked and not indicate the true consequence of the accident.

4.2.3.2 The cost established in the courts of a severe injury versus a fatality is often about the same.

4.2.4 Casualty Expectation is a measure of risk. Whereas hazard describes the intensity of the effect, for example the intensity of the overpressure loads from an explosion over a region. Risk takes into consideration the extent and probability of the explosion hazard together with where the people are with respect to the explosion and their vulnerability to the explosive effects.

4.2.5 The simplest Equation for calculating E_c is

$$E_c = P_E P_{I|E} \times N_F \times A_C \times N_P / A_P$$

where

P_E is the probability of the event. This can be the probability of failure resulting in a particular failure response mode occurring during a brief interval of flight time, Δt (a failure response mode is the dynamic characteristics, such as a tumble turn, that occurs due to a particular vehicle failure);

$P_{I|E}$ is the conditional probability given the event (failure response mode occurring during Δt) that fragments of a particular fragment group (a group contains fragments with common characteristics such as their weights, ballistic coefficients, etc.) will land on a particular population centre;

N_F is the number of fragments in the group

A_C is the casualty area associated with each fragment in the particular fragment group. Casualty area is a region within which an individual is a casualty due to direct fragment impact, explosive effects from impact, secondary debris caused by roof penetration, etc

N_P is the number of people in the population centre; and

A_P is the area of the population centre.

Note that the ratio of N_P/A_P is the population density of the population centre.

4.2.6 The above E_c is for a single event (particular failure response mode of the vehicle occurring during a specific Δt) for one class of fragments and for a specified population center assumed to have uniformly distributed population. This equation would be appropriate for calculating the E_c arising from sub-orbital missions because they can be described by few events, can be geographically contained, and would not need to overfly population centres.

4.2.7 The potential risks posed by commercial satellite launch services on the other hand present more complex hazard scenarios that need to be addressed in a more comprehensive manner. This is achieved by adopting an equation for calculating E_c that embraces the general case.

4.2.8 The more general definition of casualty expectation for a particular time interval is

$$E_c = (1 - P_{pf}) \sum_i P_i \sum_j \sum_k P_{I,ijk} \times N_{f,j} \times A_{C,ij} \times D_{p,k}$$

where the subscripts i , j and k are the indices for failure mode, fragment group and population centre, respectively, and

P_{pf} = probability of failure from any failure mode prior to the current time interval (note that if the vehicle failure rate is sufficiently low, the value of $1 - P_f$ is always near 1.0 and can be assumed to be 1.0 without significantly affecting the risk calculations)

- P_i = probability of failure mode i occurring during the time interval
 $P_{i,j,k}$ = probability of impact for failure mode i , fragment category j and population centre k
 $A_{c,j}$ = casualty area for failure mode i , fragment j
 $N_{f,j}$ = number of fragments in fragment category j
 $N_{p,k}$ = number of people in population centre k
 $A_{p,k}$ = area of population centre k
 $D_{p,k} = N_{p,k} / A_{p,k}$ = population density for population centre k

- 4.2.9 For the prediction of the risk (E_c) prior to a launch, the failure rate of the vehicle is considered. To do this, the flight time of the vehicle is usually divided in many very short successive time intervals. During each of these time intervals each of the credible response modes are considered as they derive from the vehicle failure modes. (Candidate vehicle failure response modes are failure on-course [explosion or thrust termination], malfunction turn off-course ranging from gradual to severe turns, failure to initially pitch over, gross azimuth malfunction, etc.). For each of these modes the debris footprint (impact distributions for all categories of debris) is computed for the debris predicted to result from the particular failure response mode and failure time interval, Δt . The footprint is then used to compute the impact probability for each fragment category for each affected population area. Then the corresponding E_c is computed for each fragment for each population centre and these are summed over all fragments and population centres, resulting in the conditional E_c given that the failure response mode occurs during Δt . This is then repeated for each of the credible modes of vehicle failure that could occur during the time interval Δt . If there is a Range Safety System (man-in-the-loop or autonomous) it may activate and terminate thrust and possibly break up the vehicle during the vehicle malfunction. This action should also be modeled to more accurately determine where debris would impact.
- 4.2.10 In order to get the E_c contribution for the time interval, the probability for each mode of failure is introduced. This is generally computed from the predicted or assumed rates of the failure response modes by multiplying the rates by the duration of the short time interval. The E_c contribution is then multiplied by this probability. To account for the fact that the vehicle cannot fail during the current time interval if it has already failed at an earlier time, the result is also multiplied by the probability that the vehicle has not already failed, which is computed from the total failure rate (versus time, all failure modes) up to the time of the current time interval. Typically this last probability is very close to 1.0 and does not significantly alter the resulting E_c .
- 4.2.11 The E_c for a small time interval, as defined above, could be interpreted as an “instantaneous” E_c , although the value of E_c will be dependent on the particular value selected for the duration of the time interval. Note that the failure probability for a segment of flight time covering the small time interval (say for a segment of flight during which the projected debris pattern is crossing over a densely populated area) could be set to a selected value (with corresponding values for each failure mode that add up to this failure probability) so as to emphasise the risk potential in that segment. Note also that, in general, a given population centre will be exposed to the hazard for more than one time interval. Thus, the contribution of a single interval would not be comparable to an acceptable risk criterion for the total risk to the population centre.

- 4.2.12 The total collective E_c for the mission, or for a specified segment of flight, is computed by summing the E_c values for all applicable time intervals. The E_c for specific population centres can be computed by considering each population centre separately in the above process (i.e. by eliminating the summation over population centres, considering only a single centre).
- 4.2.13 Calculating the E_c for the return of spent booster stages and fairings can be performed with the understanding that the event has a probability of 1.0 (actually [1 – probability of failure to that point in flight]). Further details for analysing this case are in Section 5.
- 4.2.14 Each element of the general E_c computation is described in greater detail below.

4.3 **Mutually Exclusive Events**

- 4.3.1 Because E_c is a function of the probability of failure and other potentially variable parameters, it also must have changing and mutually exclusive values at each failure time interval, Δt . Individual E_c calculations for each time interval are mutually exclusive because they are derived from mutually exclusive failure probabilities.
- 4.3.2 An extension of the mutually exclusive concept dictates that it is inaccurate to add the E_c of the first stage of flight to the E_c from the second stage of flight to get a total E_c and ignore the fact that a vehicle that fails during first stage cannot fail during second stage. The failure during the second stage can only occur when there is no failure during the first stage of flight. This problem is accounted for by the expression $(1-P_f)$ in the E_c general equation and is best illustrated by using an event tree.
- 4.3.3 Consider a hypothetical mission involving a vehicle with three primary periods of flight (stage I, stage II and return from orbit) with the probability of failure during the first stage of 0.1, the probability during the second stage of 0.1, and the probability during re-entry of 0.05. In addition, assume that the average consequences in terms of casualties given a Stage failure are:

$$E_c \text{ (given a Stage I failure)} = 0.00015,$$

$$E_c \text{ (given a stage II failure)} = 0.00010, \text{ and}$$

$$E_c \text{ (given a failure during reentry)} = 0.00005.$$

- 4.3.4 If the failures in the previous periods of flight were to be ignored in the event tree (See Figure 1), then the probability of failure during Stage II is 0.10 instead of the 0.09 in the figure; and the corresponding probability of failure during reentry is 0.05 instead of the 0.045 in the figure. If these probabilities are used and substituted into the figure, the total E_c becomes 27.5×10^{-6} instead of the correct value of 26.25×10^{-6} . (Note: The digits after the decimal point are shown here to help demonstrate the computation, but this type of analysis generally does not have an accuracy to warrant more than two significant figures, i. e., in this case, 26.25×10^{-6} becomes 26×10^{-6} .)

The process shown above should really be done continuously through flight (e.g. you cannot fail at 100 seconds if you have already failed at 50 seconds). By ignoring conditionality of the probabilities, the risks are always overestimated, although the effect is less as the estimated failure rate decreases.

- 4.3.5 The event tree for the example above is shown in Figure 1.

Period of Flight			Combined prob.	Consequence given the event (Ec given failure in the particular Stage)	Ec given period of flight
Stage I flight	Stage II flight	Return from orbit			
Stage I fails			0.100	0.00015	15.0×10^{-6}
prob = 0.1					
Stage I succeeds			0.090	0.0001	9.00×10^{-6}
Stage II fails					
prob = 0.9			0.0405	0.00005	2.025×10^{-6}
Stage II succeeds					
Reentry fails			0.7695	0	0
prob = 0.1					
Reentry succeeds			0.7695	0	0
prob = 0.05					
prob = 0.95			0.7695	0	0
Total					
					26.0×10^{-6}

Figure 1. Sample Event Tree to Illustrate Ec Computed with Consideration of Failure Conditional upon Success in the Previous Stage

4.4 Computing Probability of Failure

- 4.4.1 The probability of each possible outcome can be divided into the probability of success (P_s) and the probability of failure (P_f). The sum of these probabilities must be equal to 1.0 and can be expressed as:

$$P_s + P_f = 1.0$$

Where P_f represents the value of the probability of failure (all failure modes) at a discrete time interval during a launch event (eg first stage boost). If P_i represents the probability of failure mode i occurring during the discrete time interval, the probability of any failure mode occurring, P_f is defined by $\sum P_i$.

- 4.4.2 The probability of failure can be determined from historical records for mature launch vehicles or from comparative analyses and engineering failure mode analyses (eg Failure Mode Effects and Criticality Analysis) for new launch vehicles. Although it is recognised that actual mishaps often differ from predicted outcomes, failure analysis nevertheless serves as a valuable tool for assessing the potential risk to public safety.
- 4.4.3 Launch vehicles can be classified into four categories when considering failure probability: new ELVs, new RLVs, mature ELVs and mature RLVs. The determination of failure probability is easiest with the mature vehicles because it can be based on statistics from actual launch history. For new vehicles, the problem is different. Vehicle development organizations have tended to use optimistic estimates of reliability and corresponding failure probability because of their desire to claim a high likelihood of mission success. On the other hand, range safety organizations have felt it necessary to require more, sometimes much more, conservative estimates in support of their responsibilities to protect people and property on and near their ranges.
- 4.4.4 The best basis for an estimate of the performance of a new vehicle is how other vehicles of its class have performed in the past, and this is the basis of the approach used here. It is also reasonable to separate ELVs and RLVs because the RLV will have redundancies and robustness in some systems that should either reduce the failure rate or provide less risky abort modes where recovery is a goal and, presumably, because of the greater investment in quality control.
- 4.4.5 Use of the total failure probability of a vehicle alone is not sufficient for a risk analysis. Where an estimate of mission failure probability is adequate from a mission performance standpoint, the failure probability for a risk analysis must be broken down into separate vehicle failure response modes for a sequence of time intervals. It is appropriate to use a mechanism such as an event tree to show all of the different responses and then allocate probabilities for each of the responses. There are two options for obtaining the conditional probabilities for the different responses:
- 4.5.1 Generic probabilities based on the general experience of all vehicles over the last 10 to 20 years; or
- 4.5.2 Probabilities based upon the manufacturer's own failure mode and effect analyses and reliability analyses.
- 4.4.6 Failure probability for a specified flight time interval divided by the length of the interval yields a failure rate, if the failure rate over that time period is assumed constant. Failure rate is frequently higher earlier in the flight and thus the failure rate can decrease over the powered flight period. In that case, the integral of the failure rate over time is equal to the failure probability. If there is no direct evidence of this decrease, then a constant rate can be assumed. Note that the

failure rate is determined over periods of powered flight only and not over coast periods. Thus if a launch is over 500 seconds of operation with 200 seconds of coast, then the powered flight phase for failure rate considerations is 300 seconds. There can be event-related failures (staging, failure of an engine to start, etc.) and these should be given consideration not as rates but as discrete probabilities at those particular times. During an exoatmospheric coast phase the IIP does not move, thus any failure during that time can be treated like an event-related failure, i.e. discrete.

4.4.7 The following models are to be used for all classes of vehicles:

The following equation is to be used for calculating the failure probability¹ for ELVs and RLVs.

$$P_f = \frac{ax + r}{x + n}$$

where n is the number of launches of a vehicle and r is the number of failures. "a" is a failure probability assigned to a first launch. For instance, from actual ELV launch history about 25% of the new vehicles have failed, thus we will assign $a = 0.25$.³ The parameter x is an arbitrary factor that weighs the importance of general vehicle flight experience (past history of ELVs) against the actual flight experience of this particular vehicle (r failures in n launches). "x" can have any value from zero to infinity. If $x = 0$, no credit is given to past generic flight experience and if $x = \infty$, no credit is given to actual flight experience of the vehicle. We will propose $x = 4$ because it starts with the generic launch experience but allows the computed P_f to adapt fairly rapidly to actual flight experience. Thus for ELVs

$$P_f = \frac{0.25 \times 4 + r}{4 + n} = \frac{1 + r}{4 + n}$$

For RLVs, consideration may be given to the higher levels of redundancy and other features that establish high reliability and reusability, where the licensee can demonstrate that a new RLV will have reliability greater than a new ELV. To date, the only RLV is the man-rated Space Shuttle which by actual experience (as of 1 March 01) has a failure probability of 1/102 based on number of failures, r, divided by number of launches, n. It is assumed that at the time of a first launch no RLV can be proven to have the Space Shuttle reliability. However, to account for the expected higher reliability of RLVs, a model is proposed that allows a new RLV to have a failure probability between that of a new ELV and the Space Shuttle. Assume a lognormal probability distribution characterizing the uncertainty in the estimate of the failure probability of the new RLV. Let the 5-percentile of the cumulative probability distribution be set at the 0.01 probability level (corresponding to the Space Shuttle) and the 95-percentile set at the 0.25 probability (that of a new ELV).

The prior mean estimate of the new RLV failure probability is then calculated as follows:

¹ A failure for purposes of public safety must fall into the category of having a consequence that could lead to harm to people or property. Thus achieving a wrong orbit does not apply.

² The process is a Bayesian statistical process using a beta distribution and a "normalization" factor, A. The equation could be written as $P_f = (r_0A + r)/(n_0A + n)$ where r_0 and n_0 are the "prior" number of failures and "prior" number of launches respectively. The term "prior" is a Bayesian term representing augmented data.

³ The use of 0.25 is probably conservative, because a number of the new vehicle failures have been mission failures but have not been of the type to affect public safety.

Given that the 5-percentile and 95-percentile are 0.25 and 0.01, respectively, then:

$$\text{lognormal median, } M = [(95\text{-percentile}) \cdot (5\text{-percentile})]^{1/2} = (0.25 \cdot 0.01)^{1/2} = 0.05$$

$$\text{error factor, } K = [(95\text{-percentile}) / (5\text{-percentile})]^{1/2} = (0.25 / 0.01)^{1/2} = 5$$

$$\text{standard deviation, } \sigma = \ln(K) / 1.65 = 0.9754$$

$$\text{mean, } m = M \exp(\sigma^2 / 2) = 0.080$$

= the proposed value of "a" for RLVs

The P_f equation for RLVs becomes (using $x=4$)

$$P_f = \frac{0.08 \times 4 + r}{4 + n} = \frac{0.32 + r}{4 + n}$$

Note that whereas the P_f equation given for new ELVs should be considered normative for P_f computation, the above equation for RLVs must be considered indicative and cannot be adopted before the licensee provides sufficient evidence that the proposed new RLV will indeed have reliability greater than that for a new ELV.

The tables that follow show some scenarios that reflect how P_f could change with flight experience

Table 1. P_f Computations for Several ELV Launch Sequences ($a=0.25$, $x=4$)

Condition	P_f before 1 st Launch	P_f after last Launch
ELV succeeds on 1 st launch	0.25	0.20
ELV fails on 1 st launch	0.25	0.40
ELV succeeds on 1 st 5 launches	0.25	0.111
ELV has one failure in 5 launches	0.25	0.222
ELV succeeds on 1 st 10 launches	0.25	0.071
ELV has one failure in 10 launches	0.25	0.143

Table 2. P_f Computations for Several RLV Launch Sequences ($a=0.08$, $x=4$)

Condition	P_f before 1 st Launch	P_f after last Launch
RLV succeeds on 1 st launch	0.08	0.064
RLV fails on 1 st launch	0.08	0.264
RLV succeeds on 1 st 5 launches	0.08	0.036
RLV has one failure in 5 launches	0.08	0.147
RLV succeeds on 1 st 10 launches	0.08	0.023
RLV has one failure in 10 launches	0.08	0.094

⁴ If one were to continue to adhere strictly to the Bayesian methodology, the update to a posterior estimate of P_f would be done with a lognormal instead of a beta distribution. However, the beta form is easier and within the accuracy requirements of the problem.

⁵ For the experimental confidence for a proportion, r/n , see Natrella, Mary Gibbons, "Experimental Statistics," National Bureau of Standards Handbook 91, U. S. Dept. of Commerce, Washington, D.C., USA, August 1, 1963.

Table 3. Failure Probabilities for Vehicles

n	r=0		r=1		r=2		r=3		r=4		r=5	
	r/n	P_f	r/n	P_f	r/n	P_f	r/n	P_f	r/n	P_f	r/n	P_f
0	-	0.250										
1	0	0.200	1.000	0.400								
2	0	0.167	0.500	0.333	1.000	0.500						
3	0	0.143	0.333	0.286	0.667	0.429	1.000	0.571				
4	0	0.125	0.250	0.250	0.500	0.375	0.750	0.500	1.000	0.625		
5	0	0.111	0.200	0.222	0.400	0.333	0.600	0.444	0.800	0.556	1.000	0.667
6	0	0.100	0.167	0.200	0.333	0.300	0.500	0.400	0.667	0.500	0.833	0.600
7	0	0.091	0.143	0.182	0.286	0.273	0.429	0.364	0.571	0.455	0.714	0.545
8	0	0.083	0.125	0.167	0.250	0.250	0.375	0.333	0.500	0.417	0.625	0.500
9	0	0.077	0.111	0.154	0.222	0.231	0.333	0.308	0.444	0.385	0.556	0.462
10	0	0.071	0.100	0.143	0.200	0.214	0.300	0.286	0.400	0.357	0.500	0.429
12	0	0.063	0.083	0.125	0.167	0.188	0.250	0.250	0.333	0.313	0.417	0.375
15	0	0.053	0.067	0.105	0.133	0.158	0.200	0.211	0.267	0.263	0.333	0.316
20	0	0.042	0.050	0.083	0.100	0.125	0.150	0.167	0.200	0.208	0.250	0.250
25	0	0.034	0.040	0.069	0.080	0.103	0.120	0.138	0.160	0.172	0.200	0.207
30	0	0.029	0.033	0.059	0.067	0.088	0.100	0.118	0.133	0.147	0.167	0.176
35	0	0.026	0.029	0.051	0.057	0.077	0.086	0.103	0.114	0.128	0.143	0.154
40	0	0.023	0.025	0.045	0.050	0.068	0.075	0.091	0.100	0.114	0.125	0.136
45	0	0.020	0.022	0.041	0.044	0.061	0.067	0.082	0.089	0.102	0.111	0.122
50	0	0.019	0.020	0.037	0.040	0.056	0.060	0.074	0.080	0.093	0.100	0.111
75	0	0.013	0.013	0.025	0.027	0.038	0.040	0.051	0.053	0.063	0.067	0.076
100	0	0.010	0.010	0.019	0.020	0.029	0.030	0.038	0.040	0.048	0.050	0.058

Vehicles with Combinations of New and Old Subsystems

Vehicles change; they may switch or add stages or change guidance systems. This complicates the definition of flight experience per the definitions presented above. The most conservative approach is to consider a vehicle subsystem change as making the vehicle go back to being a new vehicle with no flight experience. This can be used as the starting point. If the applicant does change a stage, for example, but wants to claim successful flight experience for the rest of the vehicle, he must first develop a subsystem failure probability model using the vehicle prior to modification that allocates probabilities to subsystems and sums to the P_f as formulated above. He must then assume no flight experience for the entire vehicle, i.e. use the new vehicle formulation given above, and determine what allocation would be given to that element that is new. The probability of failure of the new element resulting from the allocation is then introduced into the original model to produce a new system failure probability. It is important that in the process of performing a risk analysis, that the period of performance of the new element must reflect the higher failure probability rate.

This method can also be applied to RLVs that have the opportunity to test part of the system repeatedly before the first launch of the integrated system. Those parts of the system that have been proven can be assigned a lower failure probability while those untested elements must conform to the general rules described above.

A simple example of this method is illustrated in Table 4. Assume a two-stage vehicle that has been launched many times and has an established failure probability equal to 0.04. Assume also, based on experience and manufacturer FMEAs, etc., that the failure probability is allocated as follows:

- (1) Stage I propulsion P_f is 35% of the system P_f ,
- (2) Stage II propulsion P_f is 35% of the system P_f and
- (3) Guidance and control P_f is 30% of the system P_f .

The applicant chooses to change the Stage II propulsion. What is the revised total P_f for the system?

Table 4. Revised Vehicle System Failure Probabilities

	Total Failure Probability, P_f		
	P_f , Orig. System = 0.04	P_f , All New System = 0.25	P_f , Modified System
Stage I Engine – 35%	0.014	0.0875	0.014
Stage II Engine – 35%	0.014	0.0875	0.0875
Guidance and Control – 30%	0.012	0.075	0.012
Revised Total Probability, P_f			0.1135

Another case is when a mature vehicle has an added new stage. In this case, the first step assumes that the vehicle is entirely new and the probabilities are allocated accordingly. The second step goes back to the original vehicle and computes the allocation and resulting failure probabilities based on actual experience. In the final step, the numbers for the mature stages/systems are substituted into the model based on the new system. This produces a P_f model that has a lower failure probability than an all new vehicle, but has a higher failure probability than the original mature vehicle and allocates the higher failure rate to the new stage.

4.4.8 Allocation of response modes and determination of failure rate

A risk analysis uses the failure rate of the vehicle, which normally varies with the stage of flight. If data about the vehicle that indicate otherwise are not available, the failure probability can be allocated evenly between each stage of flight unless the vehicle is part mature and part new as discussed above. The failure rate is generally higher at the beginning of stage operation because of the possibility of failure to start. Again if data are not available, a small percentage of the failure probability of the stage (e. g. 5%) can be assigned to the startup failure probability. The remaining failure probability of the stage can be distributed uniformly over the time of powered flight of the stage unless there are data that indicate that the failure rate will not be constant.

The vehicle response due to the malfunction is important. If the failure initiates a turn that can move the vehicle off the nominal flight path, it will produce dispersions in the impact points of the intact vehicle or the vehicle debris into areas away from the nominal trajectory. These types of failures need to be accounted for separately from those failures that produce engine shutdown or other failures that do not cause deviations of the vehicle from the nominal flight path prior to vehicle breakup or initiation of free fall.

Example: Using the example from 4.7, assume that the powered flight time of Stage I is 100 seconds and that of Stage II is 200 seconds. Table 5 gives the failure rate of the modified system in Table 4.⁶

⁶ This example does not take into consideration the discussion in Section 3.5 where a failure in Stage II cannot occur if Stage I has already failed. Ignoring this produces a small conservatism in the results, but makes the mathematics easier.

Table 5. Vehicle Failure Rates

	Failure probability and failure rate
Failure probability for Stage I engine start-up	= $0.02 \times 0.014 = 0.00028$
Engine failure rate during Stage I operation	= $0.98 \times 0.014 / 100$ = 0.000137 failures/sec
Guidance and control failure rate during Stage I and Stage II operation	= $0.012 / 300$ = 0.00004 failures/sec
Failure probability for Stage II engine start-up	= $0.02 \times 0.0875 = 0.00175$
Failure rate during Stage II operation	= $0.98 \times 0.0875 / 200$ = 0.000429 failures/sec

Table 5 defines the assignment of failure probabilities and failure rates between stages but does not allocate between vehicle responses that stay within the trajectory plane versus those that deviate off to the right or left. Assume that when the guidance and control fails it produces motion out of the plane of the trajectory 66% of the time. The failure probabilities and failure rates are now allocated as shown in Table 6.

Table 6. Vehicle Failure Rates and Probabilities Allocated Between Failure Response Modes

	Failure probability and failure rate	
	On-trajectory response mode (in-plane)	Off-trajectory response mode (out of plane)
Failure probability for Stage I engine start-up	0.00028 (from previous table)	0.0
Failure rate during Stage I operation	Engine + 0.33 of G&C failure rate = $0.000137 + 0.33 \times 0.00004$ = 0.00015	0.666 of G&C failure rate = 0.666×0.00004 = 0.0000266
Failure probability for Stage II engine start-up	0.00175 (from previous table)	0.0
Failure rate during Stage II operation	Engine + 0.33 of G&C failure rate = $0.000429 + 0.33 \times 0.00004$ = 0.000442	0.666 of G&C failure rate = 0.666×0.00004 = 0.0000266

This example demonstrates the computation and allocation of failure probabilities and failure rates for two different response modes. The particular allocations are for demonstration only and should not be the basis of a licensee computation. The computation by the licensee should either be based upon vehicle history, FMEA or general launch vehicle experience.

4.4.9 Generic allocation of failure probabilities

Table 7 was developed from actual launch history of a variety of ELVs. It allocates the probability of failure between a number of generic failure

classifications. The numbers in the table are intended to provide guidance to what may be expected, but should not be used in a risk analysis for a vehicle unless there are no vehicle specific sources. If they are used, the values should be varied parametrically to determine if the final results of the risk analysis are materially affected by the particular allocation of probabilities.

Table 7. Probabilities of Various Vehicle Failure Modes Based on International Launch Vehicle Data (1987-2000)⁷

Failure Mode	Vehicle Response	Percentage of failures (out of 100%)
Engine failure to start	Vehicle has no thrust, forward acceleration ends	5.7%
Failure of engine to reignite	Vehicle has no thrust, forward acceleration ends	7.1%
Control system – loss of thrust vector control	Vehicle tumbles or turns away from the velocity vector at the time of the failure	10.0%
Guidance and control – loss of vehicle attitude reference	Either the vehicle moves in a different plane than the intended trajectory plane or takes on a new heading and moves stably in that direction	4.3%
Engine shutdown, loss of thrust	Vehicle stops accelerating, stays intact unless it is destroyed by RS or breaks up aerodynamically	30.0%
Explosion somewhere in the liquid propulsion system	Vehicle loses thrust and breaks up with some high velocity fragments	7.1%
Solid rocket motor explosion	Vehicle loses thrust and can produce high velocity fragments	2.9%
Pitch attitude error, failure	Pitch attitude wrong but vehicle remains in the original trajectory plane	4.3%
Stage, booster or payload separation failure	Hang-up of separation or preliminary separation can lead to various abort behaviors (aerodynamic breakup, explosions, etc.)	15.7%
Software error	Can lead to wrong orbital condition or affect the control system response	4.3%
Steering or thrust failure leading to improper orbital insertion	Not considered a failure mode that affect public safety	8.6%

4.4.10 Any flight that is launched internally in the country or over another country has the potential for causing debris to fall on people. For launches of new vehicles, the following criteria must be met:

4.4.10.1 The preflight risk prediction that includes the phased reliability criteria must fall within the required Launch Safety Standards.

4.4.10.2 An unproven vehicle may be restricted from flying in the vicinity of significantly populated areas.

4.4.11 As indicated in Section 2, a $P_f = 1.0$ can be adopted when calculating E_c for spent ELV stages being returned to earth as the failure mode can be described as propulsion system shutdown.

⁷ Based primarily on data from "World Space Briefing," January 2001, Teal Group Corporation

- 4.4.12 Unproven vehicles are those that have not achieved five consecutive missions without a catastrophic failure (a failure that could conceivably hazard life and property) and therefore are subject to the phased reliability criteria.
- 4.4.13 A significantly populated area includes a township or settlement but not a homestead.

4.5 Computing Probability of Impact and Casualty Expectation for Different Flight Phases

Calculating Downrange Risk by the Corridor Method

- 4.5.1 A relatively simple risk analysis procedure can be used if the risks to be computed are downrange of the general launch area, do not involve return from orbit and do not involve actions due to range safety criteria that will distort the impact distributions. The elements of the methodology are pictured in Figure 2.
- 4.5.2 The equations associated with the methodology are as follows:

Impact Probability on a population centre: $P_I = P_I(\text{downrange}) \times P_I(\text{crossrange})$

where

$$P_I(\text{downrange}) = (\text{failure rate}) \times (A_{\text{pop}})^{1/2} / (\text{IIP rate})$$

$$P_I(\text{crossrange}) = \int p(y) dy \quad \text{where the integration limits are } y_c - \frac{1}{2} (A_{\text{pop}})^{1/2} \text{ and } y_c + \frac{1}{2} (A_{\text{pop}})^{1/2}$$

and where $p(y)$ is the probability density function for crossrange dispersion for the particular fragment category. The US FAA has published Advisory Circular 431.35-1 "Expected Casualty Calculations for Commercial Space Launch and Reentry Missions" which provides appropriate equations for calculating the probability of debris impact on populated areas. Further information is also available in the FAA document "Supplemental Guidance for Unguided Suborbital Launch Vehicles" which can be found on website http://ast.faa.gov/contest/saq_uslv.htm.

- 4.5.3 The casualty expectation assuming fragment group "i" is hazarding a specific population centre or asset is calculated by using the following equation:

$$E_{Ci} = P_I \times N_{\text{frag}} \times A_{\text{cas. frag.}} \times N_{\text{pop}} / A_{\text{pop}}$$

(Note P_I is a product of the probabilities described in Figure 2)

The total casualty expectation E_C from all fragment groups on the population centre is:

$$E_C = \sum E_{Ci}$$

This method must be applied to all potentially affected population centres to obtain the total casualty expectation. Development of the population library is discussed in the section on Population Density. The impact points used in the above analysis are drag corrected and associated with the appropriate fragment group.

A further issue in relation to public risk due to the landing of re-entry vehicles or expended ELV stages is that the landing area or exclusion zone must be sufficiently large to ensure that the returning vehicle or stage will land there with a high degree of predictability. The landing size or footprint is to be calculated by adopting four standard deviations (4-sigma) to the nominal dispersal characteristics of the returning vehicle. The 4-sigma footprint describes the area where the vehicle will land with a 0.99967 probability assuming that no major

system failure has occurred. Any major failure would therefore be considered under the standard accident debris scenario rather than as a planned return.

4.5.4 A simpler version of the corridor method uses only the vacuum impact points and groups all of the casualty areas of all the fragments into a single casualty area. This will produce approximate results that can be used in mission planning, but should not be used for a final casualty expectation prediction.

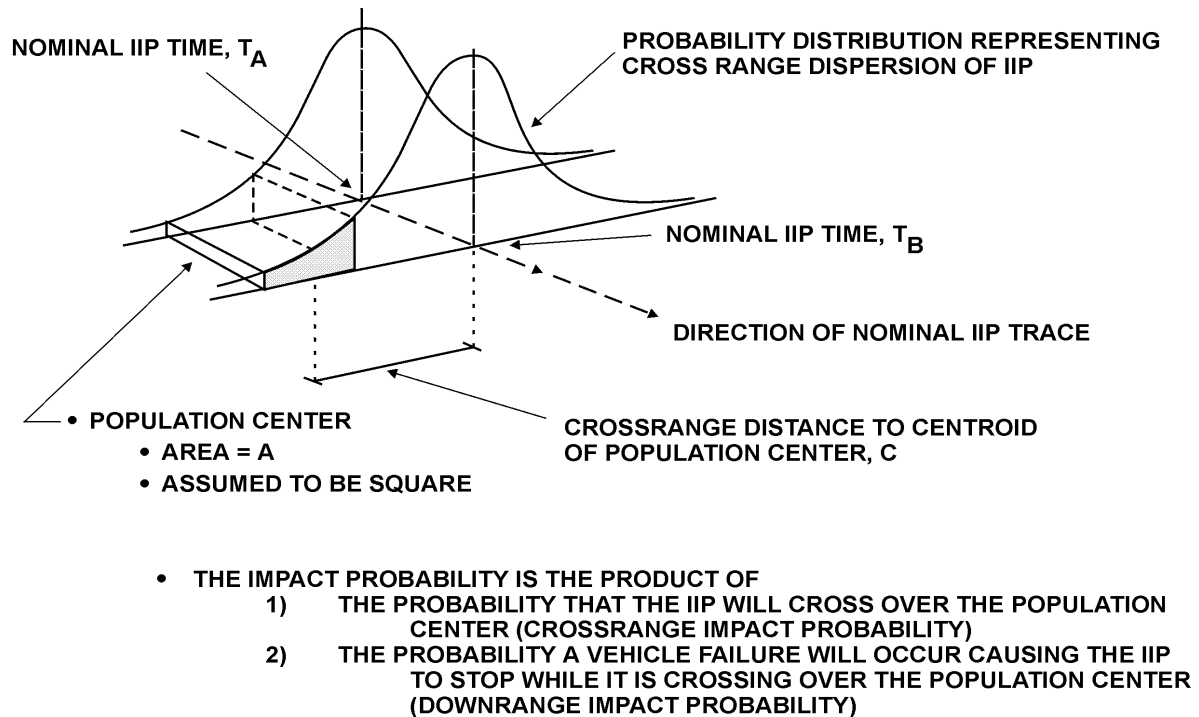

Figure 2. Diagram of the Elements of the Downrange Corridor Methodology

4.5.5 In using the method described in 4.5.4, one should be cautioned that it could easily underestimate the crossrange effects of debris. If the crossrange standard deviation is based on the normal variations in the guidance and performance of the vehicle, it will be ignoring any velocity imparted to the debris from any explosion or other energy release in the breakup and also any malfunction/tumble behavior of the vehicle prior to breakup or abort. Thus, some perturbation analysis must be performed beforehand to produce crossrange uncertainties due to perturbations to the debris and perturbations due to malfunction behavior. These standard deviations can be root sum squared with the guidance and performance dispersions. If the results indicate marginal risk acceptability, it may be wise to consider performing a more robust debris footprint methodology that can simulate the actions of the range safety abort system.

Calculating Risk from Scheduled Debris (Spent Stages, Fairings etc)

4.5.6 During an ELV launch, certain elements of the rocket are jettisoned as the launch progresses. As each stage burns out, it is separated and follows a ballistic path to impact. In addition, certain other panels, fairings, etc. may be jettisoned. This scheduled debris happens with every successful launch and thus the mission must be planned carefully such that these items of debris do not create an unacceptable risk.

4.5.7 The procedure to compute the scheduled debris risk is as follows:

- 4.5.7.1 Define the state vector (position and velocity) of the stage at the time of jettison.
- 4.5.7.2 Determine the aerodynamic characteristics of the spent stage (drag coefficient, aerodynamic reference area, weight) and compute a drag corrected impact point. Consideration should be given as to whether the stage tumbles or stabilizes at a particular attitude during descent.
- 4.5.7.3 Develop impact uncertainties of the stage based on the uncertainties in the vehicle state vector at the time of jettison (is the vehicle flying fast, slow, high, low, right or left?). Also consider any perturbation velocities that may be applied during jettison, the effect of winds and wind uncertainties and aerodynamic lift effects. This process should produce a standard deviation of impact uncertainty in the uprange and downrange direction and another standard deviation in the crossrange direction. A more sophisticated analysis may produce an impact covariance matrix representing the impact dispersions that may indicate some rotation of the dispersions relative to the downrange and crossrange directions, but this is normally of secondary significance.
- 4.5.7.4 Using the standard deviations computed above, assume a bivariate normal distribution with its mean at the nominal impact point and with its two axes aligned respectively with the downrange direction and the crossrange direction (orthogonal). Note that if the dispersion along the uprange-downrange direction is large, the uprange dispersion component will be smaller than the downrange component. If this is the case, the analyst has the option of adjusting the nominal impact point to make the distribution symmetrical in the uprange-downrange direction, or to use a different standard deviation for the uprange direction than that for the downrange direction.
- 4.7.5.5 If there is an island, offshore oil platform, or any other population centre that is potentially at risk, the impact probability can be computed by integrating under the bivariate normal distribution. Figure 3 and the equation presented in Section 4.5.8 show the bivariate normal distribution, the threatened impact area, A , and the equation for computing the probability of impact.

Probability of lying in a rectangle bounded by $x_2 < x < x_1$ and $y_2 < y < y_1$ is the volume bounded by the rectangle on the bottom and the surface on the top

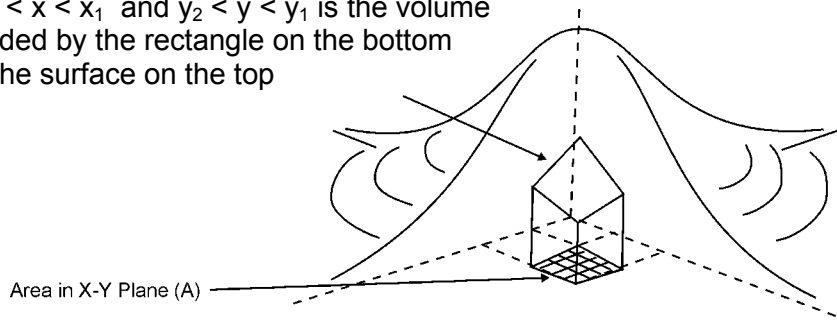

Figure 3. Bivariate Normal Distribution Showing Impact Uncertainty and the Area at Risk

- 4.5.8 The equation below is the calculation of the impact probability of a single object in an area, A, where the impact distribution is a bivariate normal distribution with the major and minor axes aligned along the x and y directions, respectively. The centre of the area, A, is at (x_A, y_A) . Assume that x is in the downrange direction, and y is crossrange, positive to the left looking downrange. The mean for this distribution is assumed to be at the nominal impact location for the stage (or fairing or fragment), thus $\mu_x = \mu_y = 0$. For small values of P_I and few impacting stages/fragments, the individual P_I can be multiplied by the number of stages/fragments to get the total P_I .

$$P_I = \frac{1}{\sqrt{2\pi}\sigma_x} \int_{x_A - \sqrt{A}/2}^{x_A + \sqrt{A}/2} e^{-\frac{x^2}{2\sigma_x^2}} dx \cdot \frac{1}{\sqrt{2\pi}\sigma_y} \int_{y_A - \sqrt{A}/2}^{y_A + \sqrt{A}/2} e^{-\frac{y^2}{2\sigma_y^2}} dy^8$$

- 4.5.9 The above process should be repeated for every jettisoned of stages, fairings, etc. Unless they are dropped together and have similar ballistic characteristics, the risks from each piece should be treated separately. When using this method it is important to realise that stages, fairings, etc. cannot be grouped in the same bivariate distribution unless they have the same mean impact point and downrange and crossrange uncertainties. If they do not, a new distribution must be computed for each. Two or more identical objects jettisoned at the same time can be treated together, however, and the impact probability (for relatively small P_I) is simply the product of the number of objects times the P_I for one. The same is true for casualty expectation, E_C , which can now be calculated from the equation in Section 5.3 above.
- 4.5.10 Probability-of-impact isopleths show the geographic distribution of impact probability on a map and depend on application. The isopleth positions change with the area of the people or place at risk, with the size of the debris fragments and the number of debris fragments. For example, the 1×10^{-7} P_I isopleth for impact on a person for a spent stage represents a boundary outside of which the

⁸ When \sqrt{A} is \ll than σ_x and σ_y , the equation in 5.8 can be simplified to be $P_I = A/(2\pi \sigma_x \sigma_y) \times \exp[-1/2((x_A/\sigma_x)^2 + (y_A/\sigma_y)^2)]$

stage will impact on a person only once in 10^7 opportunities. The 1×10^{-7} P_I isopleth on a large facility for that same spent stage would be further away from the nominal impact point than the 1×10^{-7} P_I isopleth on a person, because of the facility's larger size.

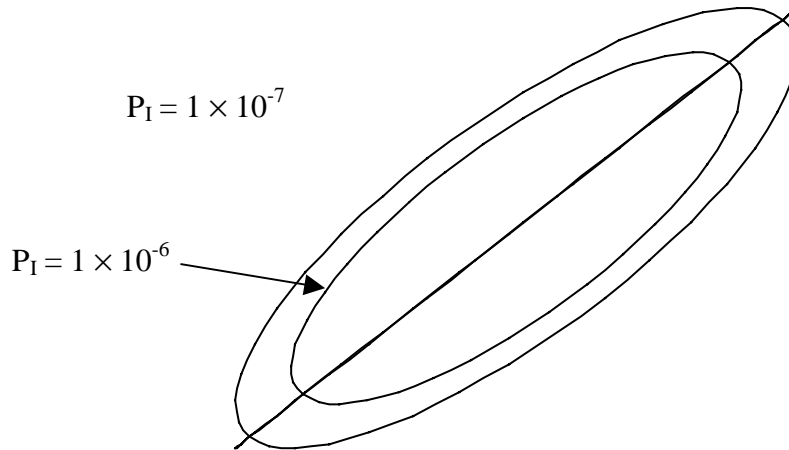

Figure 4. Sample P_I Isopleths

Calculating Risk from Failures in the Launch Area

4.5.11 Launch area risks are the most difficult to compute. At this time in flight, the IIP is not moving rapidly downrange and consequently the corridor method of risk analysis is not appropriate. Moreover, the abort criteria play a very important part and are used to restrain the motion not only laterally but also from moving back toward the launch site. Thus the analysis must model aborts in multiple directions. The programs to model all the aspects of launch area risks have become very elaborate. This discussion proposes a general approach along with certain requirements for sufficiency. One reference that offers insight into a more elaborate methodology is a paper by Baeker, Haber and Collins⁹. The procedure that follows suggests a Monte Carlo methodology.

- Establish the nominal trajectory and the normal deviations around the trajectory due to variations in performance and steering.
- Compute the malfunction turn behaviour of the vehicle if it goes into a tumble turn, normally assuming that the turn can be in any direction. Do this every several seconds of flight as necessary and for different thrust offset angles ranging from minimum to maximum. Assign a probability distribution to the likelihood of the magnitude of the thrust offset angle, given that the vehicle is in a malfunction turn.
- Determine the maximum product of dynamic pressure and angle of attack allowable by the structural design of the vehicle.
- Develop a debris list by category of ballistic coefficient
- Start a simulation just after lift-off. Randomly select a thrust offset angle and fly a malfunction turn until vehicle breakup or violation of abort criteria (the abort criteria can be based on vehicle attitude, violation of an abort limit line

⁹ Baeker, James B., Jon D. Collins and Jerold Haber, "Launch Risk Analysis," *Journal of Spacecraft and Rockets*, Vol. 14, No. 12, December 1977, pp 733-738.

by the vacuum IIP or other). At breakup calculate the drag-corrected trajectories of each debris category using a randomly selected wind profile (generated by varying the wind using the mean wind and a wind uncertainty model). Repeat this process many many times for that initial failure time and then collect the impact data in separate groups for each debris category. Develop mean and impact covariances for each debris category to form a bivariate normal distribution. The bivariate normal distribution is of the same form as that used for the impact dispersion of empty stages. The next step of the sequence is to compute the impact probability for each population centre and the corresponding casualty expectation. All of these calculations are weighted according to the failure probability during that interval. The casualty expectations are stored for each population centre.

The above sequence is repeated for each flight time interval. The method is valid both for the launch area and beyond the launch area. The total casualty expectation is the sum of the casualty expectations from each time interval.

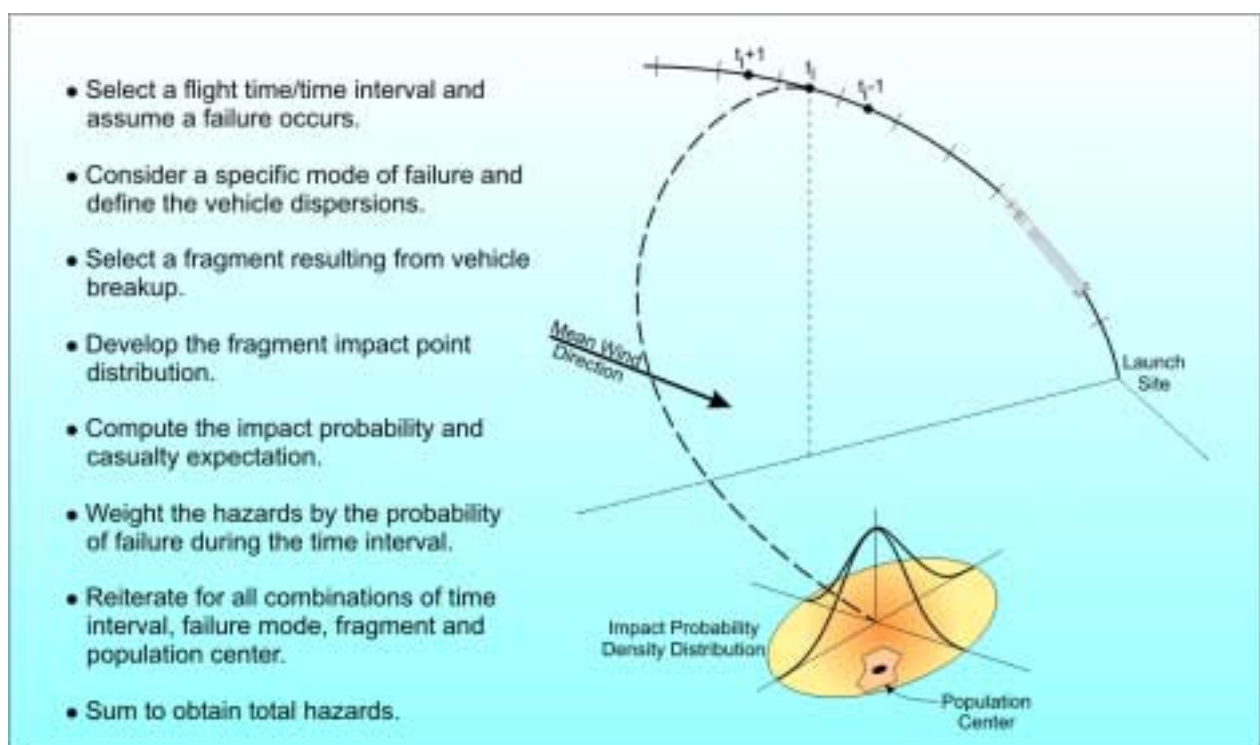

Figure 5. Iterative Procedure to Compute Risks

4.5.12 Impact probability isopleths can be computed by establishing a grid with an impact area at each intersection of the grid. An impact area size is then defined. For example, if the probability of impacting on a person is the objective then use an area of one square metre. If impact probability is needed for a larger area, e.g. a large building of 100 m by 100 m, then use an area of 10,000 square metres. Once the impact probability has been computed for each of the grid points, contours (isopleths) can be drawn that represent constant levels of impact probability.

4.6 Establishing a Debris Catalogue

4.6.1 Historically two methods have been used to define the debris that results from the destruct or breakup of a launch vehicle. The first is to use the vehicle breakup data provided by the vehicle manufacturer as part of the requirements

for launch. These data includes the various parameters required for risk analysis such as fragment ballistic coefficient, weight, projected area and imparted velocity at breakup. Usually these data pertain to the debris that would result if flight termination action (destruct or thrust termination) were taken on the vehicle. These data are reviewed by the range safety organisation, or its supporting contractors, to verify its reasonableness/validity. Also the data may be improved using specially developed breakup models. This is particularly true for the debris resulting from the pressure rupture or destruct of a solid rocket motor, where models have been developed to predict the sizes and weights of the resulting pieces of solid propellant and motor casing. Data for other modes of vehicle breakup, such as breakup due to an explosion of the vehicle or due to aerodynamic and inertial loads acting on the vehicle, are usually estimated based on the flight termination breakup data, although in some cases the vehicle manufacturer may provide data for these other breakup modes.

- 4.6.2 The second method used to define the debris is to obtain from the vehicle manufacturer a detailed listing of the various parts and components making up the vehicle. This list is then used, with the aid of the manufacturer's structural engineers, to estimate the various pieces that will result. The parameters defining the debris pieces (ballistic coefficient, weight, projected area, etc.) are then computed based on the characteristics of the pieces. Velocities imparted due to an in-flight explosion are estimated using various software models. In fact these models also attempt to predict the sizes and weights of the fragments resulting from an explosion, but usually the results need to be "massaged" to get a reasonable debris list.
- 4.6.3 For the purpose of performing risk analyses, the debris data are grouped into "fragment groups" consisting of fragments having similar characteristics. Average characteristics are then computed and applied to all fragments in the group.

4.7 Computing Casualty Area

- 4.7.1 When debris impacts, there is a region on the ground in which a person who is present will become a casualty. The definition of casualty is severe injury (at least a visit to the hospital) or death. A person can become a casualty both outside and inside a shelter because of:
- 4.7.1.1 direct impact from debris,
 - 4.7.1.2 being struck inside the structure from debris created by the fragment (e.g. roof failure),
 - 4.7.1.3 direct overpressure and impulse from an explosion of vehicle or propellant and
 - 4.7.1.4 debris effects internal to a structure on occupants due to a nearby explosion of a vehicle or propellant.
- 4.7.2 Characteristics of the debris that affect the casualty area are cross-sectional area, impact velocity, weight, impact angle, drag coefficient, and explosivity. Also the number of fragments is essential, since it is normally assumed that each fragment will land sufficiently away from any other to make the likelihood of two fragments striking the same person very unlikely. This is assumed to be the case too with explosive fragments that can have much larger casualty areas.
- 4.7.3 The issues to be considered when calculating casualty area include the effects of inert debris falling vertically and/or ricocheting, explosive debris, debris fragment size and number (debris catalogue), horizontal and vertical cross-sectional area of the "standard person", angle of impact, and calculation of the composite or

effective casualty area. All of the above debris scenarios will depend on the type of launch vehicle failure e.g. the debris casualty area for a launch vehicle impacting intact can be expected to be significantly less than for an in-air explosive failure. Four underlying assumptions to be adopted are that

- (1) the debris catalogue converts the total non-volatile mass of the launch vehicle (including payloads) into fragments that are potentially casualty producing,
- (2) all fragments with weight and impact velocity above a specified threshold, either striking a person directly or glancing a person will result in death or serious injury,
- (3) no individual debris casualty areas overlap, and
- (4) the dimensions of a “standard person” are 0.3 metres in radius and 2.0 metres in height.

4.7.4 A methodology for calculating Casualty Area A_c is presented in the US FAA Advisory Circular mentioned above and for the information of and use by applicants is summarised below. However, the preferred methodology for calculating Casualty Area is addressed in a more comprehensive manner in Appendix 1.

4.7.5 The equation for calculating Casualty Area A_c is expressed as follows:

$$A_c = A_{c(\text{inert})} + A_{c(\text{explosive})}$$

where:

$A_{c(\text{inert})}$ comprises a basic component $A_{c(\text{basic})}$ which is made up of debris falling vertically and diagonally, and a ricocheting or skid component $A_{c(\text{skid})}$, and

$A_{c(\text{explosive})}$ which is the explosive debris contribution to Casualty Area calculated from converting propellant weights into equivalent TNT weights and using an explosive overpressure threshold of 25 kPa (overpressures of up to 65 kPa will be considered on a case by case basis).

$A_{c(\text{basic})}$ can be calculated as a circular area encompassing the sum of the radius of a “standard person” and the radius of the fragment (vertically falling debris) plus the projected area encompassing the radius of a person plus the radius of the fragment multiplied by the tangential height of a “standard person” (diagonally falling debris). The equation for calculating $A_{c(\text{basic})}$ is:

$$A_{c(\text{basic})} = \pi (r_p + r_f)^2 + 2(r_p + r_f)h_p$$

where:

r_p is the radius of the “standard person”,

r_f is the radius of the fragment, and

h_p is the height of the “standard person” divided by the tangent of the impact angle.

4.7.6 The figures below provide a diagrammatic clarification of how $A_{c(\text{basic})}$ is determined:

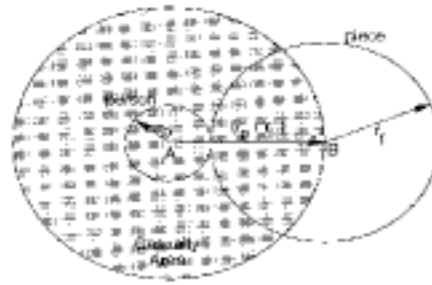

Figure 6. Debris Falling Vertically

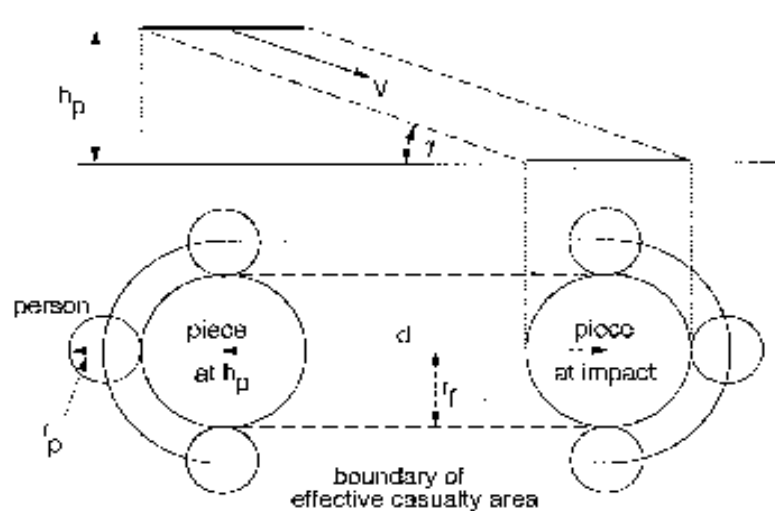

Figure 7. Debris Falling Diagonally

- 4.7.7 $A_{c(\text{skid})}$ represents the adjustment to Casualty Area resulting from ricocheting or skidding fragments. This component of A_c is addressed in a study conducted by the Research Triangle Institute - Report No RTI/5180/60-31F of 13 April 1995 that the FAA has made available through AST's Web Site. The report provides the basis for calculating $A_{c(\text{skid})}$. The study shows that the basic casualty area can be increased by a factor of 1.7 to 7.0 as a result of ricocheting or skidding fragments. The worst-case scenario using a factor of 7.0 should not be automatically adopted because factors such as altitude of the failure or type of terrain (pavement, soft ground) have a marked effect on the E_c computation.
- 4.7.8 The FAA Advisory Circular also addresses the explosive debris contribution to Casualty Area and this is summarised below:

$A_{c(\text{explosive})}$ can be calculated from the equation:

$$A_{c(\text{explosive})} = \pi R_e^2$$

where:

$$R_e = K \times W^{1/3}$$

and:

R_e is the radius for the explosive casualty area,

K is a distance scaling factor, and

W is the TNT equivalent weight of the propellant.

- 4.7.9 The factor K is addressed in a number of publications and two references provided by the US FAA are US DOD 6055.9-STD, DOD Ammunition and Explosive Safety Standards dated August 1997 and Chemical Propulsion Information Agency Publication 394, Hazards of Chemical Rockets and Propellants dated 30 June 1985.
- 4.7.10 As is mentioned above, the preferred method for calculating Casualty Area A_c has been prepared for the Australian Space Licensing and Safety Office by ACTA Inc. This methodology is fully self-contained and enables applicants to readily calculate A_c . The methodology is presented in detail in Appendix 1 and the subject matter is covered under the following headings:
- 4.7.10.1 Inert debris effects:
- people in the open; and
 - people in structures.
- 4.7.10.2 Explosive debris effects:
- determination of explosive yield - liquid propellants;
 - determination of explosive yield - solid propellants;
 - determination of overpressure and impulse;
 - impact on people in the open; and
 - impact on people in structures.
- 4.7.11 All the required equations, tables and graphs necessary for completing the calculation are provided in the methodology at Appendix 1.

4.8 Population Density

- 4.8.1 Population data must be generated for all locations that can potentially be at risk due to a launch. The population at risk is defined as that which has an individual risk of at least 10^{-9} due to debris on a per launch basis.
- 4.8.2 There are two options for defining population: distinct population centres and population density. The preference is the use of population centres because it allows for consideration of sheltering. Sheltering can be treated by percentages of the population in each sheltering category (in the open, in light shelters, etc.).
- 4.8.3 Generally, population data are required to be in more detail nearer the launch site, often requiring data for individual buildings. As the distance from the launch site increases, the data can be defined in terms of towns, cities and large open areas. To account for the rural populations, the flight corridor is usually divided into large rectangular areas to pick up the spread-out rural population. The populations in the cities and towns are, of course, not included in the populations of those rectangular areas.
- 4.8.4 The alternate form of population data is population density. It is available in regions defined by ranges of degrees or minutes of latitude and longitude. The advantage is that all of the population is accounted for. The disadvantage is that municipalities and other more densely populated areas are not efficiently defined and it is difficult to deal with sheltering. The most desirable approach is to develop population centre data down to the smallest available size and then define open area population using the population density data with the population of the accounted for municipalities removed.

4.9 Launch Safety Standards

- 4.9.1 The Casualty Expectation standard adopted must acknowledge public expectations that the risk of death or serious injury from commercial space activities should not exceed that from comparable industries. It should also be recognised that in adopting the E_c philosophy it is more difficult to accurately measure actual risk than to determine that the risk is below a certain acceptable threshold.
- 4.9.2 Collective risk is the total risk to the public from a launch. The E_c used as a measure of risk to the public for licensing purposes should be based on the total risk over all phases of flight where the public is exposed, i.e. ascent to orbit and return from orbit. Risks in orbit are generally to physical assets and not to people and thus can be excluded. The total risk as defined above is the “collective” risk.
- 4.9.3 Individual risk, i.e. the highest risk to any single person exposed to the launch, must also be controlled but limits on individual risk are not sufficient to control the collective risk. Individual risk does not take into account the number of people exposed to the hazard. Collective risk is absolutely necessary as the primary measure of mission risk. Individual risk should be included as a secondary measure that must also be satisfied at some level of acceptability but never as a sole criterion.
- 4.9.4 From a mission-planning standpoint, risks from impacting inert and exploding debris should be the primary considerations. Risks from toxic gases must be considered if the vehicle has fuels that can produce these gases either in a normal launch or an aborted launch. Distant focusing overpressure (DFO) from a ground explosion from an abort in the launch area may cause window breakage to occur up to 30 km from the launch site. Both the toxic gas risk and the DFO risk are dependent upon the weather conditions at the time of launch. They are generally looked upon as constraints on the day of launch due to weather. As a constraint they can lead to a launch hold if the launch risk including toxic and DFO risk exceeds the acceptable risk standard. These hazards are generally not considered in overflight risks.
- 4.9.5 The three criteria to be satisfied are:
- 4.9.5.1 collective risk to the public on a per launch basis (Casualty Expectation Standard);
 - 4.9.5.2 the highest risk to an individual of the public on a per launch basis; and
 - 4.9.5.3 the highest risk to an individual of the public on a per year basis.
- 4.9.6 The populations of foreign countries as well as Australia must be considered under the same criteria. Individuals supporting the launch do not have to be considered under the public risk category.
- 4.9.7 The following are the standards to be met and include ascent, descent and landing operations:
- 4.9.7.1 Casualty expectation standard 1×10^{-4} casualties per launch (collective risk).
 - 4.9.7.2 Maximum individual risk (casualty) 1×10^{-7} per launch.
 - 4.9.7.3 Maximum individual risk (casualty) 1×10^{-6} per year.
- 4.9.8 In analyzing the risk to property (designated high value assets), a different standard called the Asset Risk Standard is used. Using the probability of failure, the chance of impact, the area of the asset and the area of the debris footprint a calculation can be performed that determines the risk to the asset. If this risk of

the asset of being damaged is greater than 1×10^{-5} then the asset is under too large a risk and the flight path would need to be reconsidered. The 1×10^{-5} standard has been adopted from the US Federal Aviation Authority (FAA) advice presented in a publication titled "Supplemental Application Guidance for Unguided Suborbital Launch Vehicles." If the debris is "trigger debris," i.e. its impact could initiate a set of events that could produce great damage or many casualties, the standard for probability of impact becomes 1×10^{-7} .

- 4.9.9 During the flight of the launch vehicle it is common for one and sometimes two stages to be dropped as their fuel is consumed. Also early in flight, once the atmosphere has thinned enough, fairings that enclose and protect the satellite in its early passage through the lower atmosphere are jettisoned. Each of these pieces has a planned drop zone defined as a four standard deviation footprint that contains 0.99967 of all impacts. Within each zone, calculations are performed to determine risks to people or property. Drop zones are usually selected to be free of people. The casualty safety standards do apply in drop zones, so the launch must not proceed if any individual is within the 1×10^{-7} individual risk isopleth. If the asset risk exceeds 1×10^{-5} , or if the asset risk from "trigger debris" exceeds 1×10^{-7} , then the drop zone would be inappropriate and would need to be relocated. This method applies to drop zones on land or sea.
- 4.9.10 Applicants are required to prepare contour (isopleth) maps for the launch and re-entry phases of each mission, which present the impact probabilities and individual risk densities. The following contour (isopleth) maps are specifically required:
- (a) map showing the 1×10^{-7} individual risk isopleth and the 10^{-9} individual risk isopleth. The individual risk isopleth is to be calculated on the basis of a person in the open.
 - (b) map showing the 1×10^{-7} probability of impact isopleth for "trigger debris" on a hypothetical object of the same physical dimensions as a designated asset. (One such map for each designated asset in the vicinity and each type of "trigger debris". In this context "in the vicinity" means within 50km.)
 - (c) map of each drop zone and landing site, showing the four standard deviation controlled area and the 1×10^{-7} individual risk isopleth. (One such map for each drop zone.)
 - (d) map of each drop zone and landing site, showing the four standard deviation controlled area, the 1×10^{-7} "trigger debris" probability of impact isopleth on a hypothetical object of the same physical dimensions as a designated asset. (One such map for each designated asset, if any, in the vicinity of the drop zone or landing site and for each type of "trigger debris".)

5. CONTACT DETAILS

For further information about the licensing regime set out under the *Space Activities Act 1998*, including matters set out in this Code, interested parties should contact::

Dr Michael Green

Director

Space Licensing and Safety Office

Department of Industry, Tourism and Resources

Level 9

20 Allara Street

CANBERRA ACT 2601

Telephone: 02 6213 6986

Facsimile: 02 6213 7249

Email: Director.slaso@industry.gov.au

APPENDIX 1

PREFERRED METHODOLOGY FOR COMPUTING CASUALTY AREA

Inert Debris Effects

Inert Debris Effects on People in the Open

Several factors should be considered in the computation of casualty areas for inert debris. These include the size of the fragment, the size of a person, the velocity vector at impact, and whether the fragment remains intact after impact or disintegrates (splatters). If it stays intact, it may ricochet or slide, depending on the velocity vector (magnitude and angle), the effective coefficient of restitution and the effective coefficient of friction between the fragment and the ground. Included in ricochet are the effects of tumble as well as rebound or bounce.

For a direct impact from debris falling vertically, the casualty area takes into account both the projected area of the debris and the projected area of the human body from above. Usually, somewhat conservatively, the radius of the human body is assumed to be 0.3 m. If the velocity and weight of the fragment exceeds criteria presented in Figure A1-1, the person becomes a casualty. The criterion in Figure A1-1 is for “average general public.” The associated casualty area is

$$A_C = \pi [(A_p/\pi)^{1/2} + r_p]^2 \quad (\text{this will also referred to as the } \textit{basic casualty area})$$

where A_p = projected area of the fragment, and

r_p = representative radius of a person

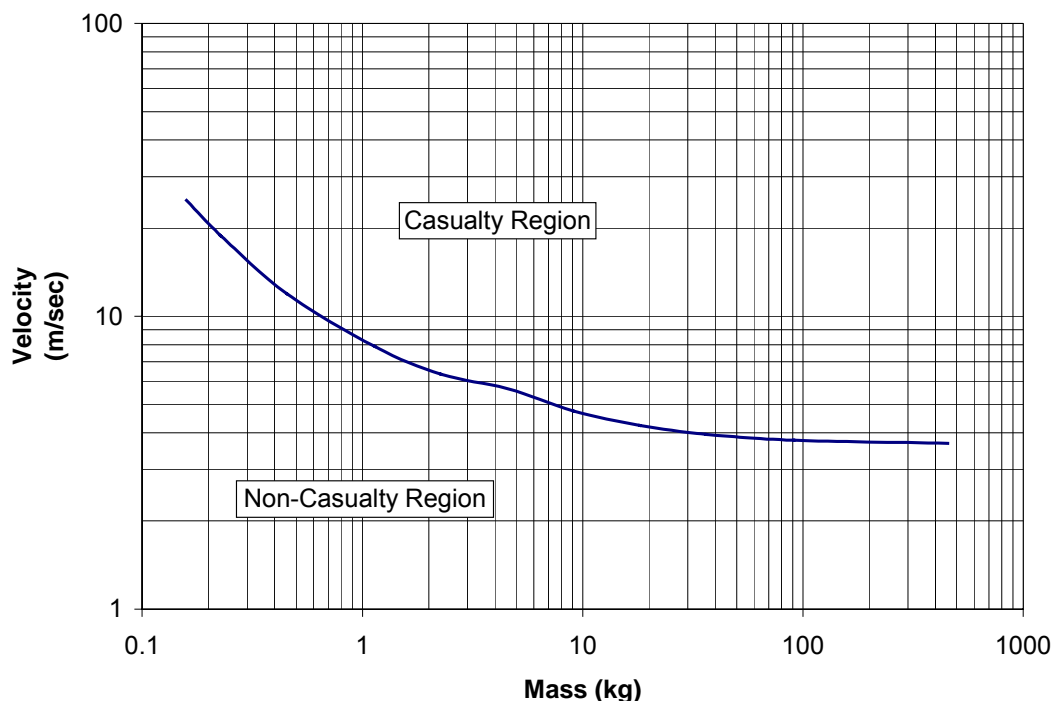
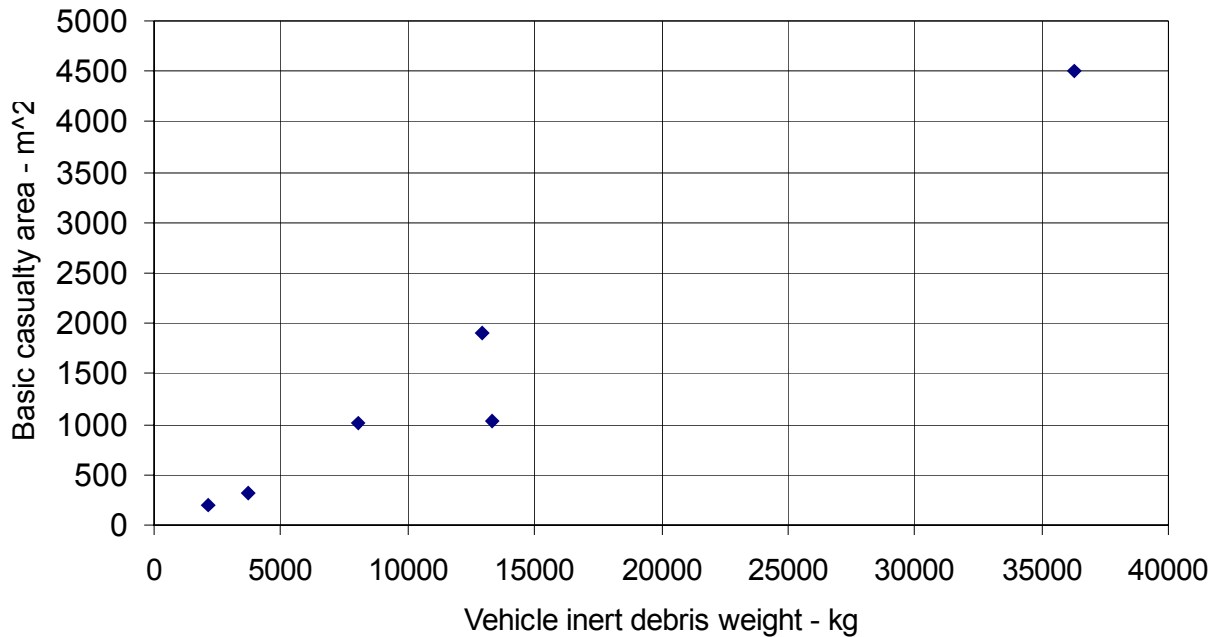

Figure A1-1. Impact Velocity Regions for Casualties and Non-Casualties

Figure A1-2 is provided as a guideline for “reasonableness” for total basic casualty area. The plot contains the total casualty area for several common ELVs (without



identification) as a function of vehicle inert debris weight, i.e. no solid or liquid propellant and no solid rocket motor casing. These numbers make use of the debris lists developed by the vehicle launch organization. There is a very distinct trend and estimates of basic casualty area should generally fall within $\pm 20\%$ of the trend line of the data.

Figure A1-2 Basic Casualty Area Versus Total Weight Of Inert Debris for Several Different Expendable Launch Vehicles

The casualty area grows when considering angular strike and the dynamic effects of impact on the ground and subsequent motion. The casualty area for impact at an angle α relative to vertical is

$$A_{\alpha} = \pi [(A_P/\pi)^{1/2} + r_P]^2 + [(A_P/\pi)^{1/2} + r_P] * h * \tan \alpha$$

where h is the reference height of a human being.

To handle the aspects of bounce, skid, roll and breakup and splatter upon impact involve speculation with shapes, coefficients of restitution, friction coefficients, and the vulnerability of people to the fragment after bounce, skid, roll, etc. This process is complex and speculative. A reasonable model covering the post impact behaviour is to multiply A_{α} by a factor of four.¹⁰ Thus, considering impact at an angle (α degrees from vertical), the recommended formula for casualty area is

$$A_{\alpha} = 4 \pi (A_P/\pi)^{1/2} + r_P)^2 + [(A_P/\pi)^{1/2} + 2r_P] h \tan \alpha$$

¹⁰ ACTA is currently performing research on post impact behavior taking into consideration a human vulnerability model. A study by Robert Montgomery and James Ward, “Casualty Areas for People in the Open from Impact Inert Debris,” (Research Triangle Institute Report No. RTI/5180/60-311, 1995) presents a fairly complete model including a splatter model. The model requires a number of assumptions of the type mentioned in the text above. The proposed factor of four (currently used by ACTA with its LARA program) provides results that are similar to the RTI results, except for the RTI splatter which can, at times, produce a much larger casualty area.

Figure A1-3 was also developed from some common ELV data. It provides the number of debris fragments as a function of inert vehicle weight. An estimate of the total basic casualty area from Figure A1-2 divided by an estimate of the number of fragments from Figure A1-3 will produce an average basic casualty area.

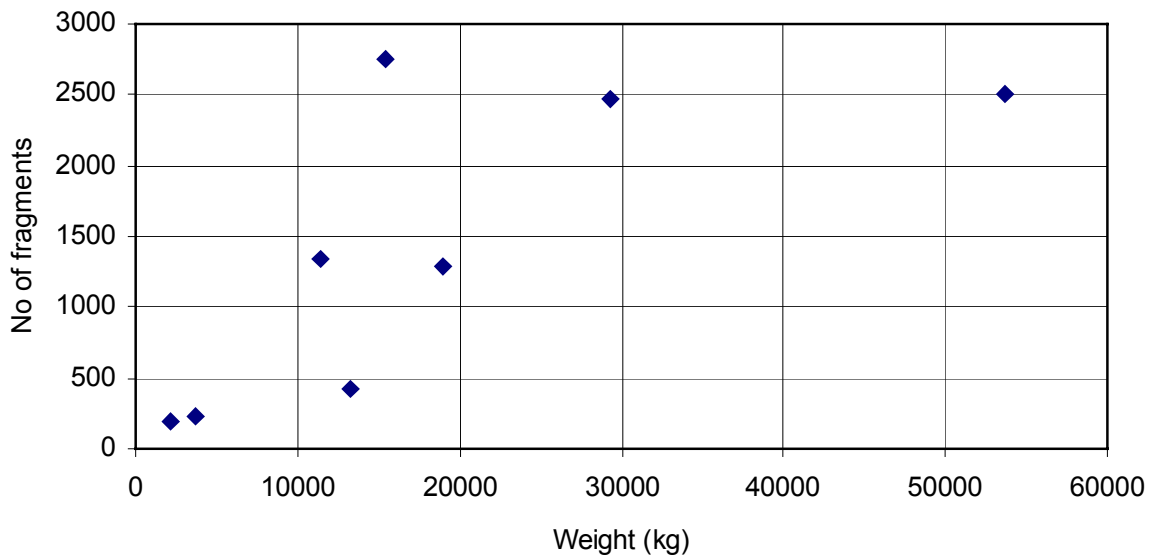

Figure A1-3. Number of Debris Fragments Versus Total Weight of Inert Debris for Several Different Expendable Launch Vehicles

Inert Debris Effects on People in Structures

If a fragment is heavy enough and the velocity is high enough, it can penetrate the roof of a structure and either impact directly on occupant or cause structural debris to impact on an occupant. Since each different location of impact on the roof will have a different effect, the work to develop relationships was performed on impacts over thousands of locations on the roofs and over many roof types that were finally apportioned into several categories. After fragment penetration into the structure and the secondary debris was determined, the same rules were applied to the vulnerability of the occupants as to people standing in the open. The result is the set of curves shown in Figures A1-4, A1-5 and A1-6 for fragments falling at terminal velocity with drag coefficients of 0.75 for high and medium, and 0.87 for low density fragments (Based on the general shapes and masses expected in each fragment group; light fragments can represent skin panels while heavy fragments can represent heavy engine equipment, and medium, the fragments in between). The vertical scale gives the average casualty area due to roof penetration for three different general roof classes. Each figure represents a different class of fragment densities. Note that as fragments weigh less and have lower impact velocities, they are less likely to penetrate. In these cases the average casualty area converges to the minimum casualty area for a person.

A subset of the numerical results is listed in Tables A1-1 to A1-3. The following trends can be noted:

- (1) The smallest casualty area is approximately 0.3 m^2 , which corresponds to the projected area of an average person with a radius of 0.3 m
- (2) No casualties internal to a structure are expected from fragments less than 0.4 kg.

Below a certain fragment weight, heavier structures tend to offer more protection, as they do not fail. However as fragments become heavy enough to fail the heavier structures, more casualties may be expected due to heavier secondary debris. Some of the irregularities of the curves may be attributed to the fact that as the fragment size increases, the fragment may no longer fit between the joists of a roof structure, hence the probability of penetrating through a relatively weak roof plate drops to zero. Meanwhile the kinetic energy may become large enough to fail the joists, resulting in steep increments of casualty area. It is similar when the fragment becomes too large to fit between the girders. These irregularities are consistent with the discontinuities observed in the individual HACK/CF¹¹ runs. Averaging over different building designs within a structure category and Principal Component Analysis tends to smooth the discontinuities.

¹¹ Technical paper on the computer program, HACK. presented by David Bogozian (Karagozian and Case) and Mark Anderson (ACTA Inc.) at the 1998 Explosives Safety Symposium, Orlando Florida.

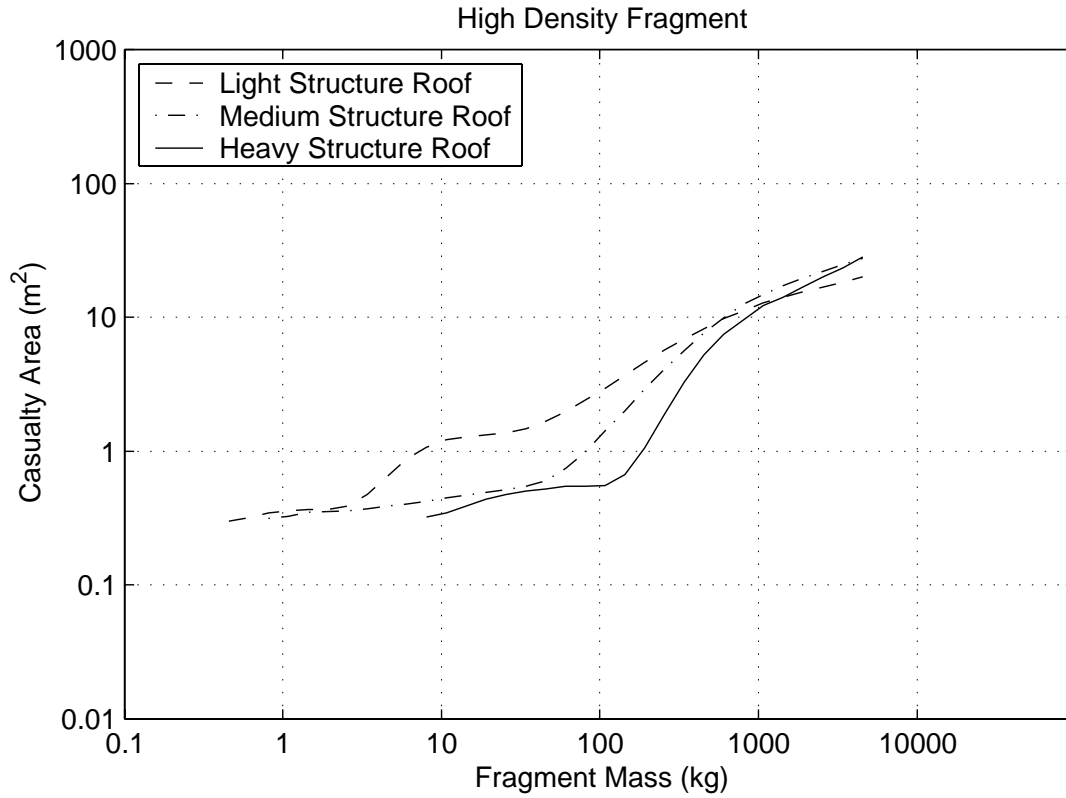

Figure A1-4. Casualty Areas for High Density Fragments (2408 kg/m^3 , $C_D=0.75$)

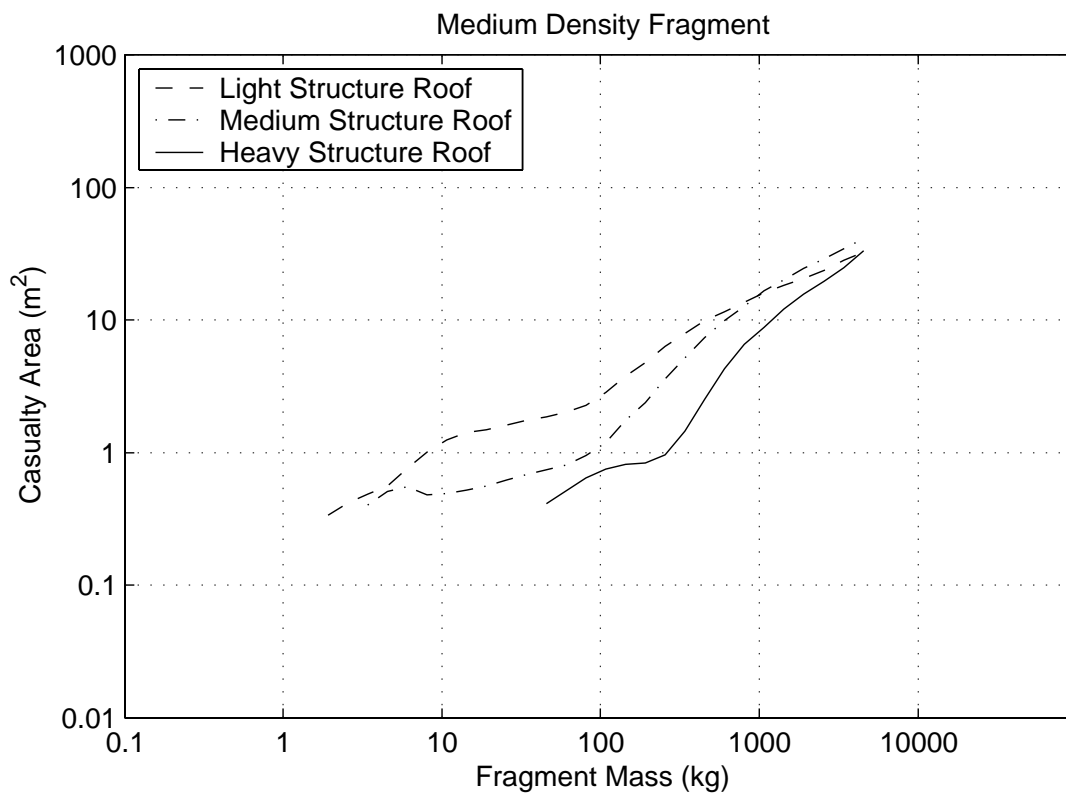

Figure A1-5. Casualty Areas for Medium Density Fragments (554 kg/m^3 , $C_D = 0.75$)

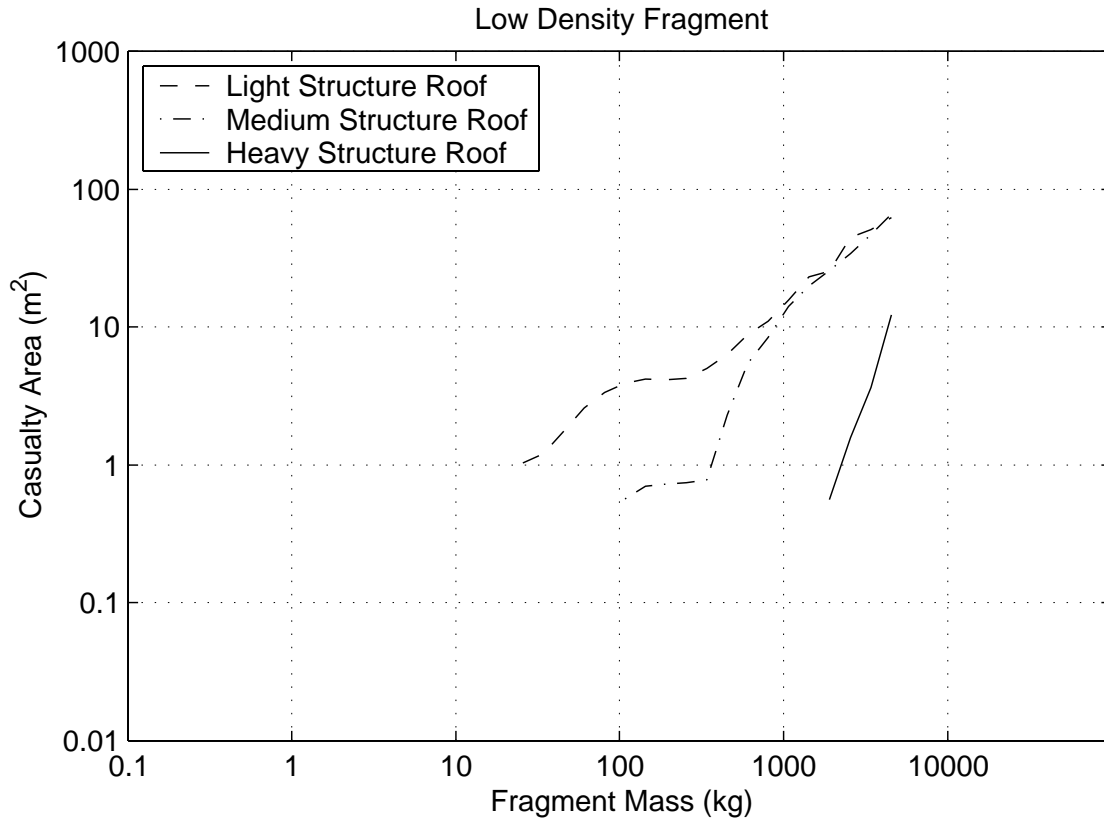

Figure A1-6. Casualty Areas for Low Density Fragments (27.7 kg/m^3 , $C_D = 0.75$)

Table A1-1. Building Casualty Area for High Density Fragments

Fragment Mass (kg)	Mean Fragment Area (m ²)	Impact Velocity (m/s)	Casualty Area (m ²)		
			Light Structure Roof	Medium Structure Roof	Heavy Structure Roof
0.045	.000708	36.9	0	0	0
0.143	0.00152	44.5	0	0	0
0.454	0.00329	54	0.301	0	0
1.43	0.00708	65.5	0.367	0.351	0
4.54	0.0152	79.2	0.646	0.387	0
14.3	0.0329	96	1.27	0.468	0.391
45.4	0.0708	116	1.66	0.604	0.522
143	0.152	141	3.7	2.01	0.665
454	0.329	171	8.17	7.67	5.26
1430	0.708	207	14.1	17.3	14.1
4540	1.52	251	20.1	27.7	28.3

Table A1-2. Building Casualty Area for Medium Density Fragments

Fragment Mass (kg)	Mean Fragment Area (m ²)	Impact Velocity (m/s)	Casualty Area (m ²)		
			Light Structure Roof	Medium Structure Roof	Heavy Structure Roof
0.045	0.00189	22.6	0	0	0
0.143	0.00406	27.3	0	0	0
0.454	0.00876	33.2	0	0	0
1.43	0.0189	40.2	0	0	0
4.54	0.0406	48.5	0.563	0.509	0
14.3	0.0876	58.8	1.41	0.519	0
45.4	0.189	71.3	1.87	0.742	0.411
143	0.406	86.3	3.75	1.75	0.821
454	0.876	105	9.94	7.36	2.53
1430	1.89	127	18.2	20.1	12.1
4540	4.06	154	32.6	41.2	33.4

Table A1-3. Building Casualty Area for Low Density Fragments

Fragment Mass (kg)	Fragment Area (m ²)	Impact Velocity (m/s)	Casualty Area (m ²)		
			Light Structure Roof	Medium Structure Roof	Heavy Structure Roof
0.045	0.0139	7.71	0	0	0
0.143	0.0299	9.36	0	0	0
0.454	0.0645	11.3	0	0	0
1.43	0.139	13.7	0	0	0
4.54	0.299	16.6	0	0	0
14.3	0.645	20.1	0	0	0
45.4	1.39	24.4	1.76	0	0
143	2.99	29.5	4.17	0.698	0
454	6.45	35.7	6.32	2.31	0
1430	13.9	43.3	23.1	19.8	0
4540	29.9	52.4	62.0	66.2	12.3

Explosive Debris Effects

Determination of Yield from Impacts of Explosive Debris – Liquid Propellants

The curves in Figure A1-7 were obtained from Project Pyro^{12,13}, which was a test program, performed in the 1960's.

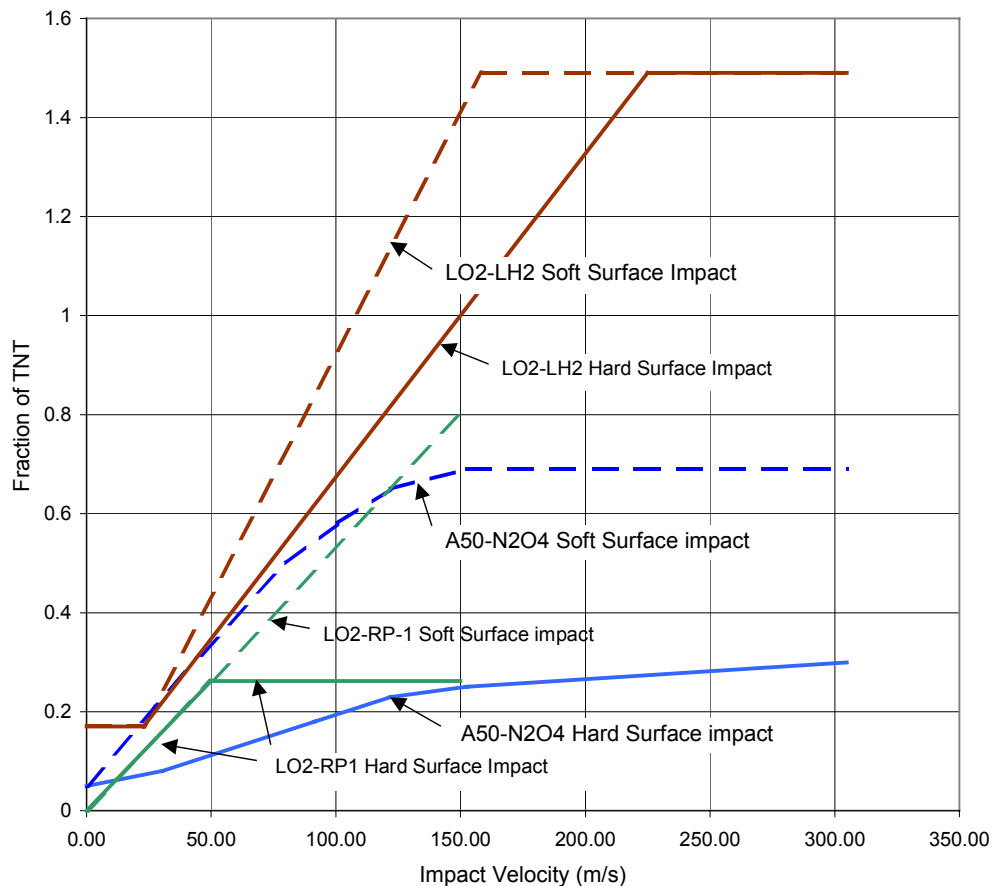

Figure A1-7. Equivalent TNT Yield of Rocket Liquid Propellant Explosions as a Function of Impact Velocity

More recent research has been performed on the yields at impacts below 50 m/s.¹⁴ However, impacts at these low velocities are not expected except very near the launch pad and thus are not included in this discussion.

¹² Willoughby, A. B., et al, Study of Liquid Propellant Blast Hazards, AFRPL-TR-65-144, URS Corp., Burlingame, CA, June 1965

¹³ Willoughby, A. B., et al, Liquid Propellant Explosive Hazards, AFRPL-TR-68-92, Vol. 1, 2, 3 URS Corp., Burlingame, CA, December 1968

¹⁴ Tomei, E. J. "Explosive Equivalence of Liquid Propellants," JANNAF conference paper presented in Houston, TX, April 21-23, 1998.

Determination of Yield from Impacts of Explosive Debris – Solid Propellants

A general formula for the equivalent TNT yield of solid propellant in an explosion resulting from impact is¹⁵

$$\text{Fraction of TNT} = 1.28 / [1 + e^a(2.2046 \times W)^b(3.2808 \times V/S)^c]$$

where W = total propellant weight (kg)

V = impact velocity (m/s)

S = surface hardness factor

S = 2.92 for water

S = 1.81 for soft soil

S = 1.41 for concrete

S = 1 for steel

a = 12.16

b = -0.156

c = -1.55

Determination of Overpressure and Impulse from an Explosion

The overpressure and impulse from an explosion can be determined by the Blast Calculator model published by Ward, et al at the Australian Ordnance Council Conference, Parari '99, in Canberra. The most recent version of the Blast Calculator Model (4) was reported by Swisdak, et al at the 2000 Explosive Safety Seminar in New Orleans, LA and is available upon request from Michael Swisdak (swisdakmm@ih.navy.mil).

Note that the impulse from a propellant explosion may be less at the same overpressure level than for a TNT explosion. However, until a substantive relation-ship is developed, it is best to use the overpressure and yield from a TNT explosion.

Explosive Debris Impact on People in the Open and People in Structures

People in the Open

For estimating the probability of slight and severe casualties from a blast wave, the following effects were considered:

1. Soft tissue effects - damage to lungs, GI tract, larynx, and eardrum (rupture for serious and temporary hearing loss for slight)
2. Whole Body Translation - general body impact only

Lovelace data for each of the soft tissue damages were used to define the combined pressure and impulse (P-I) associated with the 1% (threshold) and 50% probability of serious injury. These levels were then used to define probit functions for each effect. P-I diagrams for serious injury due to whole body translation were constructed using two different methods:

¹⁵ The above formulation was developed by Wilde and Anderson and is based on a fit to a combination of theoretical results (PIRAT program) and test data. An alternative model, which separates out impact orientation and case size, was developed by RTI and is based solely on the PIRAT theoretical results. It can be obtained from the U. S. Air Force at Patrick Air Force Base, Florida.

- 1) The TNO fatality probit function for whole body translation was scaled based on the ratio between the impact velocity for fatality and serious injury at the 50% probability level. The fatality-to-serious injury ratio was based on comparing the impact velocity at the 50% probability level based on the BEI skull fracture model for large masses;
- 2) TNO fatality probabilities for a given P and I were directly translated to serious injury probabilities by using the ratio between casualty and fatality probability based on the BEI skull fracture model for large masses;

P-I diagrams for soft tissue and whole body translation effects and for slight injury, serious injury and fatality have been developed based on the methods described above. These P-I diagrams were then used to determine the effective casualty and fatality distance as a function of yield. Figures A1-9 and A1-10 show the effective distance and a comparison against constant overpressure lines.

People in Structures

Structures are usually thought of as providing protection to people from debris and blast waves. However, a blast wave can produce considerable harm to people inside the structure, either due to flying glass shards or elements (panels, etc.) of the structure itself.

Figure A1-8 shows the general approach adopted for systematically estimating casualty probabilities. This approach¹⁶ is very similar to one used in a recent WS Atkins study to determine fatality probability functions for structures subjected to vapor cloud explosions¹⁷ (Jeffries, 1997).

The steps shown in Figure A1-8 capture the basic phenomena that define the effects of air blast loading on a structure and its occupants. First, the blast loading on the structure is defined and the window glazing is checked for breakage. If breakage occurs, the flying shards are tracked and their impact on a building occupant is used to estimate their contribution to the probability of casualty given an explosive event occurs, [P(c|e)]. After glass breakage occurs, the loads acting on the structure are revised to account for venting and the external cladding checked for failure. If wall or roof segments fail, the cladding debris is tracked and its impact on building occupants used to estimate their contribution to the probability of casualty. If the building is susceptible to collapse, the blast loads are revised again to reflect the potential for additional venting and the structure checked for collapse. If the building construction is susceptible to collapse, the impact of large building components striking occupants is used to estimate their contribution to the probability of casualty. The contributions due to glass breakage, debris throw and collapse are then combined. Depending on the level of blast loading and the type of construction, the overall casualty probability may be dominated by glazing breakage alone, or from combinations of glass breakage, cladding failure and/or collapse. Figure A1-10 includes the blast effect on occupants of a single structure type, a pre-engineered metal building with a particular glass area to floor area ratio. The curve shows that for large yields at a distance, it is more risky to be inside than outside. If the launch vehicle has the potential for a large explosion on impact, consideration should be given therefore to the risk to building occupants. The 2-psi (13.8 kPa) curve in Figure A1-10 offers a reasonable upper bound.

¹⁶ Chrostowski, Jon D. Gan, Wenshui, Wilde, Paul D., and Bogosian, David, "Generic Building Models for Air Blast Loading," Explosives safety Seminar, New Orleans, LA, July 2000.

¹⁷ Jeffries, R. M., Hunt, S. J., Gould, L. Derivation of Fatality Probability Functions for Occupants of Buildings Subject to Blast Loads, WS Atkins Science and Technology, Surrey, UK , 1997.

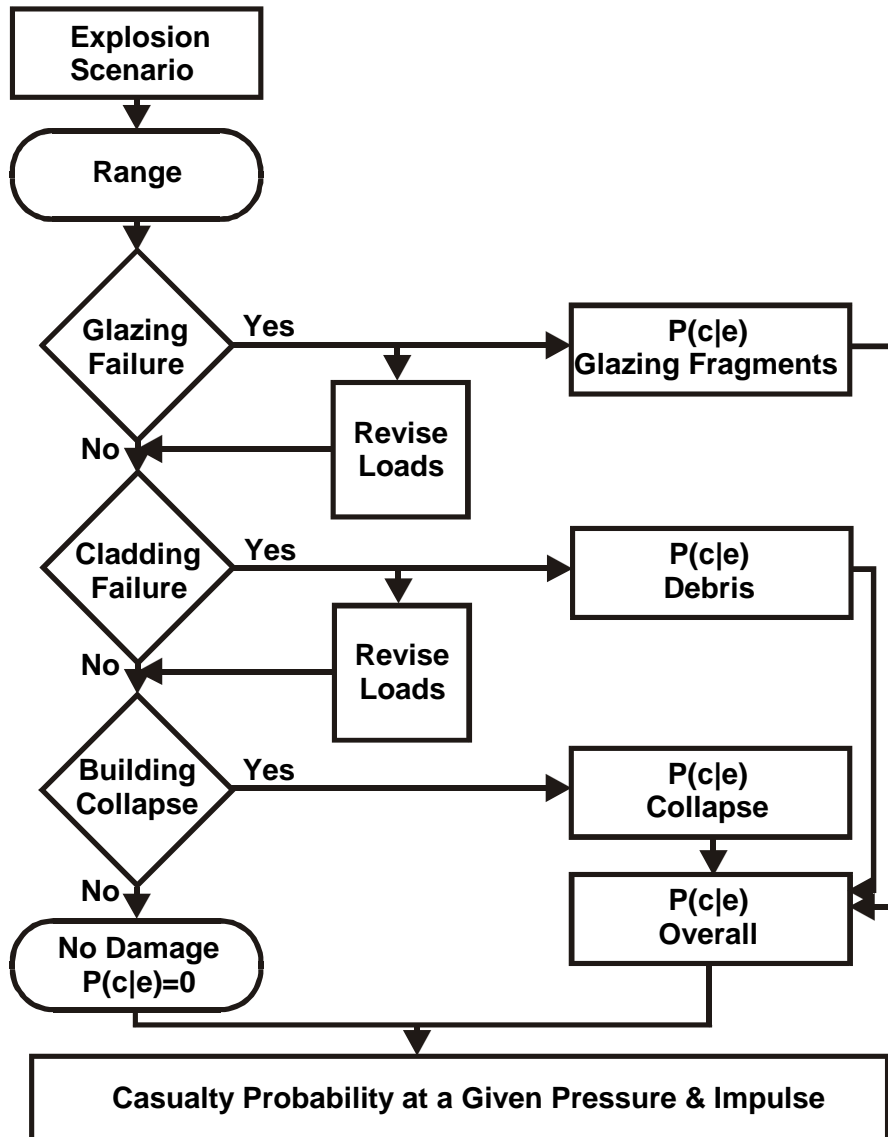

Figure A1-8. Steps for Estimating Casualty Probability Given an Explosive Event

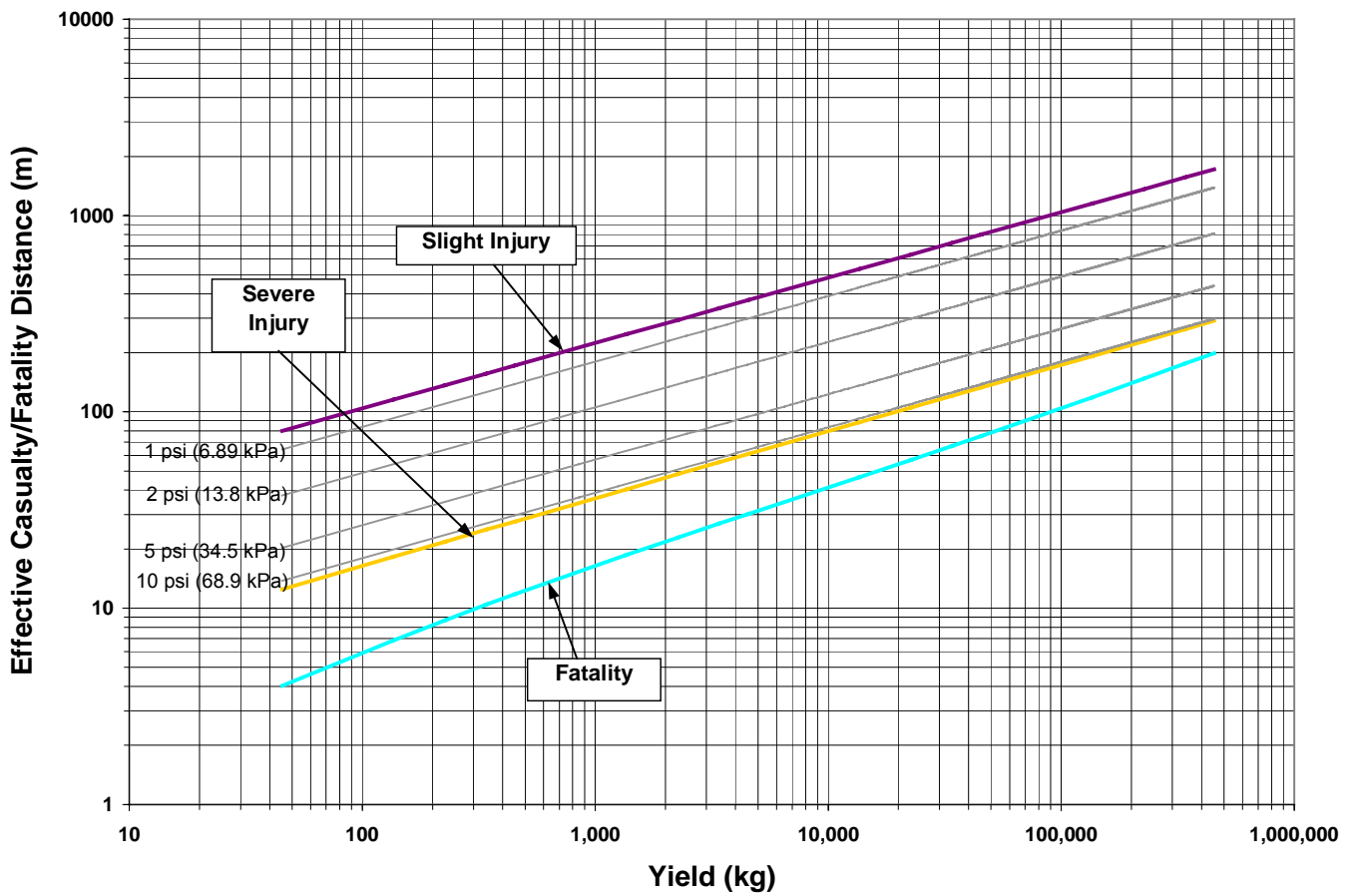

Figure A1-9. Casualty and Fatality Distance for People in the Open Exposed to a Blast Wave from an Explosion

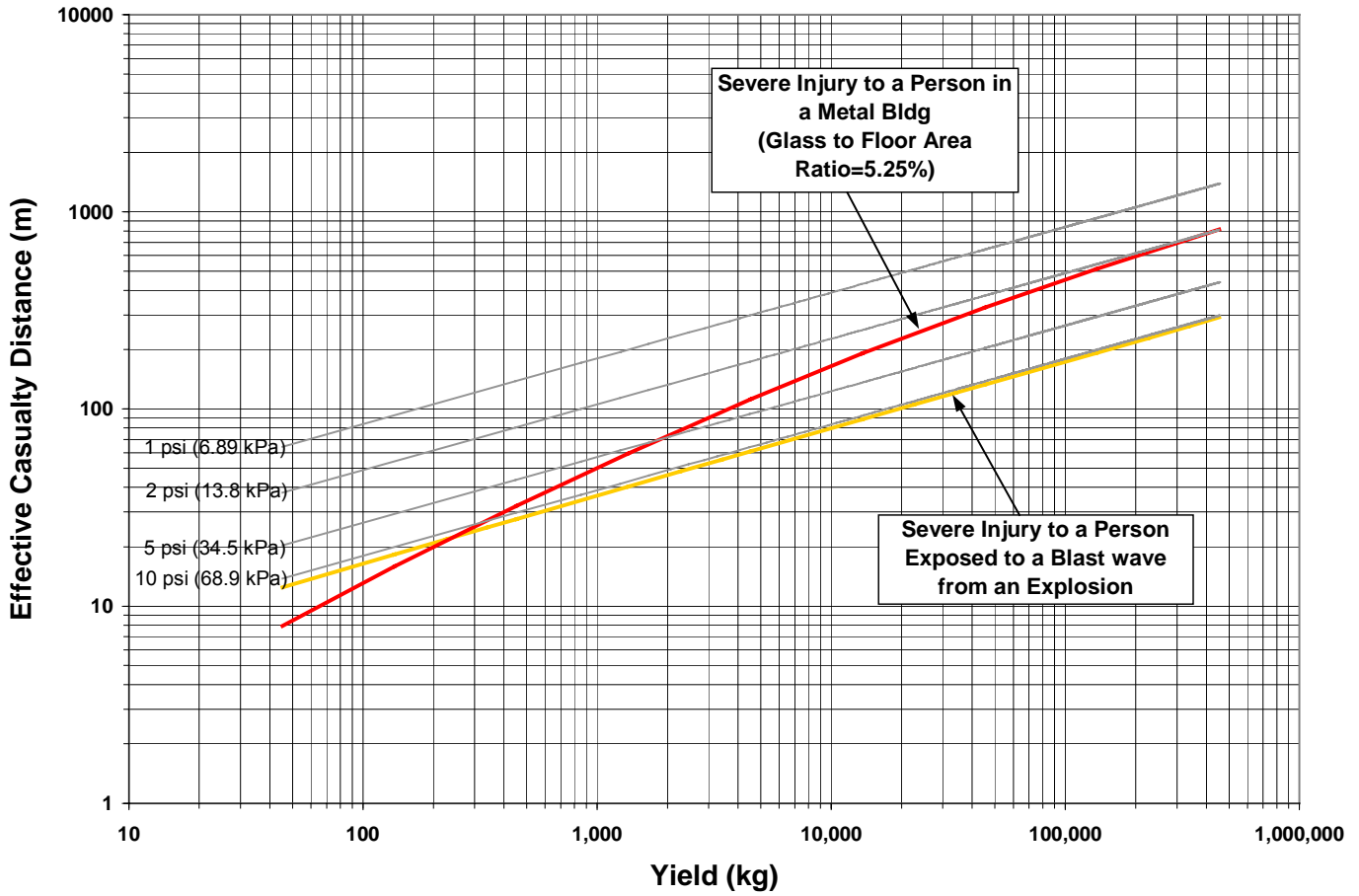

Figure A1-10. Effective Casualty Radius for Severe Injury from a Blast Wave for People in the Open or in a Light Structure

APPENDIX 2

RISK ANALYSIS EXAMPLES

1. Vehicle Description

Consider a two-stage expendable launch vehicle with the following characteristics:

- First launch
 - Using the formula for P_f , probability of failure during the first launch is 0.25
 - Assume that the total failure probability of each stage is equal, i.e. 0.125 (note that if other vehicle specific data are available that can improve the failure probability estimate it should be used)
 - Assume that the failure probability during each stage is apportioned as follows;
 - Failure of the rocket motor to ignite –10%
 - Failure of the guidance and control – leading to a malfunction turn away from the direction of the nominal velocity vector – 25%
 - Failure in the propulsion system leading to an explosion and break up of the vehicle (on-course) – 50%
- Liquid propelled (LOX and kerosene)
- First stage – 20m x 3m, inert weight = 6K kg¹⁸
- Second stage and payload – 10m x 3m, inert weight 5K kg
- Impact range of first stage = 150 km
- Vacuum IIP rate at the time of jettison of the first stage – 2 km/sec
- Impact dispersions of the jettisoned first stage
 - Down-range standard deviation = 10km
 - Cross-range standard deviation = 5km
- Basic casualty area (no bounce, slide, skip, splatter or off-vertical impact)
 - Stage I - 900 sq. metres (estimated from Appendix 1, Figure A1-2)
 - Stage II and payload - 600 sq. metres (estimated from Appendix 1, Figure A1-2)
- Estimated number of fragments
 - Stage I –800 (guessed from Appendix 1, Figure A1-3)
 - Stage II and payload – 700 (guessed from Appendix 1, Figure A1-3)

¹⁸ These numbers are purely for demonstration and may not be realistic

2. Determination of Risk to a Designated Asset from the Jettisoned First Stage

Assume that the asset has the dimension of 100 m by 100 m. To compute the impact probability of the stage on the asset, find the nominal drag-corrected impact point for the stage and locate the position of the impact point relative to the asset location. For this example, assume that the mean impact point of the stage falls 10 km short and 4 km to the left. The impact area for the computation is defined as the area of the asset increased by 1/2 booster length in each direction with a radius of 1/2 booster length filling in the corners. Using the equation in Section 4.5.8, the value of P_1 for jettisoned stage impact on the asset is $P_1 = 2.01 \times 10^{-5}$ (shown in the table from a spreadsheet that follows).

If the P_1 is to be less than 1×10^{-7} (or any other criterion), the equation in the footnote to Section 5.8 can be rearranged as follows to place a minimum value on the allowable offsets (mean impact point of the stage), x and y . The condition is satisfied if $-2[\ln(2\pi\sigma_x\sigma_y/A) + \ln(P_1)] \leq (x/\sigma_x)^2 + (y/\sigma_y)^2$ where P_1 is an input parameter in the equation. The values that satisfy this inequality for $P_1 = 1 \times 10^{-5}$, 1×10^{-6} and 1×10^{-7} for these particular values of A , σ_x and σ_y are shown below.

Table A2-1. Minimum Value of $[(x/\sigma_x)^2 + (y/\sigma_y)^2]$ Allowable to Satisfy Specified P_1

Required P_1	Minimum value of $(x/\sigma_x)^2 + (y/\sigma_y)^2$
1×10^{-5}	17.4
1×10^{-6}	27.6
1×10^{-7}	35
1×10^{-8}	41

Note in the table that follows on the next page, that when computing P_1 for a single person in the open, P_1 is never larger than 8.77×10^{-7} . This would not be true if the impact uncertainties for the stage were reduced.

If the impact probability from the empty stage on a person standing in the open is needed, then the basic casualty area (not considering breakup, slide, roll, skid, splatter or angular impact) is the plan form of the stage plus 0.3 m all around. This is approximated by the basic casualty area formulation in Appendix 1, i.e. $A_C = \pi [(A_P/\pi)^{1/2} + r_P]^2$ where A_P is the plan form area (160 m^2) and $r_P = 0.3 \text{ m}^2$. Thus, for this case, $A_C = 173.7 \text{ m}^2$. If a multiplier of 4 is introduced for post impact behaviour, and if the stage falls at 5 degrees off the vertical, the casualty area becomes 274.1 m^2 .

Tables A2-2 to A2-5 summarize the computations.

Table A2-2. Asset Dimensions and Stage Impact Dispersions

Asset length, m = 100
Asset width, m = 100
Down-range stand dev.(sigma x), km = 10
Cross-range stand dev.(sigma y), km = 5

Table A2-3. Casualty Area Computations for Impacting on a Person

Impacting stage dimensions (m)	x = 20 y = 3
Number of objects	n = 1
Half width of person (m)	rp = 0.3
Height of person (m)	h = 2
Multiplier on basic casualty area for bounce, slide, roll and splatter	M = 4
Ave. angle of impact (deg off vert))	alpha = 5
$R = (xy/\pi)^{(1/2)} + rp$, (m)	R = 4.67
$AC = M \cdot \pi \cdot R^2 + \sqrt{[(x+2rp)(y+2rp)]} \cdot h \cdot \tan(\alpha)$, (m ²)	AC = 275.5
Equivalent radius of AC, (m)	RC = 9.36

Table A2-4. Sample Computation of Risks Due to Impacts of Spent Stages on Designated Assets

Area at Risk	Asset Area (m ²)	Effective Impact Area (m ²)	DR Location in Drop Zone (x) (km)	CR Location in Drop Zone (y) (km)	(x+sqrt(A))/Sigma x	(x-sqrt(A))/Sigma x	P(x)	(y+sqrt(A))/Sigma y	(y-sqrt(A))/Sigma y	P(y)	Pi = P(x)*P(y)	Ec per Person on Designated Asset
Designated Asset	10000	14314	0	0	5.98E-03	-5.98E-03	4.77E-03	1.20E-02	-1.20E-02	9.55E-03	4.56E-05	1.26E-06
	10000	14314	5	0	5.06E-01	4.94E-01	4.21E-03	1.20E-02	-1.20E-02	9.55E-03	4.02E-05	1.11E-06
	10000	14314	10	0	1.01E+00	9.94E-01	2.89E-03	1.20E-02	-1.20E-02	9.55E-03	2.76E-05	7.61E-07
	10000	14314	-10	4	-9.94E-01	-1.01E+00	2.89E-03	8.12E-01	7.88E-01	6.93E-03	2.01E-05	5.53E-07
	10000	14314	15	0	1.51E+00	1.49E+00	1.55E-03	1.20E-02	-1.20E-02	9.55E-03	1.48E-05	4.08E-07
	10000	14314	20	0	2.01E+00	1.99E+00	6.46E-04	1.20E-02	-1.20E-02	9.55E-03	6.17E-06	1.70E-07
	10000	14314	25	0	2.51E+00	2.49E+00	2.10E-04	1.20E-02	-1.20E-02	9.55E-03	2.00E-06	5.52E-08
	10000	14314	30	0	3.01E+00	2.99E+00	5.30E-05	1.20E-02	-1.20E-02	9.55E-03	5.06E-07	1.39E-08
	10000	14314	35	0	3.51E+00	3.49E+00	1.04E-05	1.20E-02	-1.20E-02	9.55E-03	9.97E-08	2.75E-09
A person		276	0	0	8.30E-04	-8.30E-04	6.62E-04	1.66E-03	-1.66E-03	1.32E-03	8.77E-07	
		276	5	0	5.01E-01	4.99E-01	5.84E-04	1.66E-03	-1.66E-03	1.32E-03	7.74E-07	
		276	10	0	1.00E+00	9.99E-01	4.02E-04	1.66E-03	-1.66E-03	1.32E-03	5.32E-07	
		276	15	0	1.50E+00	1.50E+00	2.15E-04	1.66E-03	-1.66E-03	1.32E-03	2.85E-07	
		276	20	0	2.00E+00	2.00E+00	8.96E-05	1.66E-03	-1.66E-03	1.32E-03	1.19E-07	
		276	25	0	2.50E+00	2.50E+00	2.91E-05	1.66E-03	-1.66E-03	1.32E-03	3.85E-08	
		276	30	0	3.00E+00	3.00E+00	7.36E-06	1.66E-03	-1.66E-03	1.32E-03	9.74E-09	
		276	35	0	3.50E+00	3.50E+00	1.45E-06	1.66E-03	-1.66E-03	1.32E-03	1.92E-09	

Notes:

(1) If more than one identical objects are impacting, the total P_i for N objects = $1-(1-P_i)^N$

(2) When the area to be impacted is much larger than the stage, the impact area is defined as the area of the structure (e.g. an oil platform) increased by $1/2$ stage length in each direction with a radius of $1/2$ stage length filling in the corners.

(3) The impact area for a person is the same as the casualty area since impact by an object of this size can be assumed to always produce a casualty

Table A2-5. Offset Requirements to Keep P_i Below Specified Level

Computation of offset required to maintain P_i less than specified value for an area that is large relative to the jettisoned stage

P_i value =	1.00E-05	1.00E-06	1.00E-07	1.E-08	1.00E-09
sigma x (km) =	10	10	10	10	10
sigma y (km) =	5	5	5	5	5
impact area (km ²)=	1.43E-02	1.43E-02	1.43E-02	1.43E-02	1.43E-02
$(x/\text{sig}x)^2+(y/\text{sig}y)^2 >$	3.03	7.64	12.24	16.85	21.45
If $y=0$ then $x >$	17.4	27.6	35.0	41.0	46.3
$x/\text{sig} x =$	1.7	2.8	3.5	4.1	4.6

Computation of offset required to maintain P_i less than specified value for a single person standing in the open with the jettisoned stage breaking up upon impact

P_i value =	1.00E-05	1.00E-06	1.00E-07	1.E-08	1.00E-09
sigma x (km) =	10	10	10	10	10
sigma y (km) =	5	5	5	5	5
impact area (km ²)=	2.76E-04	2.76E-04	2.76E-04	2.76E-04	2.76E-04
$(x/\text{sig}x)^2+(y/\text{sig}y)^2 >$	Not poss.	Not poss.	4.34	8.95	13.55
If $y=0$ then $x >$	Not poss.	Not poss.	20.8	29.9	36.8
$x/\text{sig} x =$	Not poss.	Not poss.	2.1	3.0	3.7

Adjustment for Failure Probability

Technically, any vehicle that fails prior to staging will not present a risk from a jettisoned stage. In this case, it was assumed that the vehicle would fail during first stage flight with a probability of 0.125. Thus the probability of jettisoning an empty stage should be 0.875 not 1.0. Presumably then, all of the impact probability figures associated with an empty stage presented in this section should be lowered by multiplying the P_i by 0.875.

Failure of the Next Stage to Start

At staging, the first stage is jettisoned and the second stage rocket engines are ignited. If these engine(s) fail to ignite, the second stage will fall in the general region of the jettisoned first stage. The difference will be that the second stage will be full of propellant, have a higher ballistic coefficient and may break up depending upon either the action of the abort system or aerodynamic loads. The probability of this event will be the probability of having succeeded during the first stage of flight but failing at the beginning of the second. Thus,

$P_f = 0.875 \times 0.125 \times 0.10 = 0.0109$. Next, look at each case:

1. If the vehicle is aborted and the propellants are jettisoned, then the risks are similar to those of an empty stage. Note that the dimensions of the stage will be different than that of the jettisoned first stage and the nominal impact point and impact dispersions may be different because of differences in the ballistic coefficient, wind effects, etc. Since the fuel jettison takes time, the ballistic coefficient will be changing as the propellant mass in the vehicle is being reduced.
2. If there is no abort, and no vehicle break up, the stage can impact intact and explode. The rules for computing yield from an explosion upon impact are described in Appendix 1. The extent of damage from an explosion is based upon overpressure and impulse from the explosion. If there is no capability to evaluate damages to the asset more precisely, use 24 kPa as the overpressure which if exceeded will produce unacceptable damage or casualties.
3. If the stage is destroyed or breaks up aerodynamically, the propellants will be dispersed, but the casualty area will now have to take into consideration many inert pieces. The casualty area, based on weight of inert debris should fall within the range shown in Appendix 1. Appendix 1 also has a range of number of pieces as a function of total inert debris weight. When a stage or vehicle breaks up, the impact probability computation must consider the fact that the pieces spread and impact over a wider area. A simple model for computing impact probability is to divide the total casualty area by the number of pieces; this will give a single reference casualty area. Then compute the impact probability of that single piece assuming that the impact dispersions are the same for all pieces. This is not a particularly robust assumption because each fragment or fragment group could have a different mean impact point and different values for their impact dispersions. If this could have a serious affect on the conclusions of a risk analysis, then a more complete study involving debris details, trajectories and dispersions must be performed.

However, to demonstrate the effect of multiple debris pieces, this example will be continued. Assume a total inert debris mass of 6000 kg that represents approximately 800 pieces with an average fragment weight of 7.5 kg. Based on Appendix 1, a total basic casualty area of 900 m² falls within the bounds of past practice. Divided by 800, the average basic casualty area is 1.1 m². If we are interested only in whether any fragment strikes a designated asset, then the dimension of a human in the basic casualty area equation must be removed. Since $A_C = \pi [(A_P/\pi)^{1/2} + r_P]^2$ with $r_P = 0.3$ m, , the adjusted casualty area is $A' = A_P = \pi [(A_C/\pi)^{1/2} - r_P]^2 = \pi [(10/\pi)^{1/2} - 0.3]^2 = 0.267$ m². Adding the radius associated with this dimension around the 100 by 100 m designated asset gives the effective impact area associated with a small fragment hitting the asset. Using the same procedure as that for a spent stage, compute the impact probability of the smaller fragment on the asset. Then assume that all fragments are statistically independent of each other. The probability of at least one fragment impacting on the Designated Asset is $P_{IN} = 1 - [1 - P_I]^N$ where P_I is the impact probability on the Designated Asset for a single fragment and N is the number of fragments. This P_{IN} is conditional upon the probability of the second stage motor failing to ignite and the probability that the stage will break up either due to abort action or aerodynamic loads.

The lesson from the above exercise is that breaking up into many pieces increases the impact probability. On the other hand, however, the consequence of impact from any of many pieces is much less than the consequence of impact of a single intact stage and payload, with a potential ensuing explosion.

Special Consideration for Protected Assets

If Protected Assets are to be an additional 10 km radially from the 1×10^{-7} impact probability isopleth, consider using the impact probability isopleth for an intact jettisoned stage.

3. Determination of Risk to a Designated Asset and/or People from the Failure of Vehicle During Powered Flight (Down Range Beyond the Launch Area)

Downrange risks can be computed with the corridor model suggested in Section 4.5.4. This model operates, like the jettisoned stage model, with separate impact probability computations in the downrange and cross-range directions. Like the former, the cross-range uncertainty is represented by a normal distribution. However, in the downrange direction, the distribution is represented by selecting an interval of distance along the locus of the IIP¹⁹ and computing the probability that the vehicle will fail during the time that the IIP is within the interval. In this model, the interval distance is the square root of the area of a particular population centre. The cross-range impact probability is calculated using the distances from the mean path of the IIP to the inner and outer edges of the population centre. The population centre is usually assumed to be square for convenience of computation.

The table below shows that the failure rate during flight is 0.0005625. If this is during second stage flight, and the first stage had a failure probability of 0.125, and the start-up failure probability for the second stage is $0.125 \times 0.057 = 0.007125$, then the failure rate below is reduced accordingly.

Table A2-6. Failure Rate Computations

Vehicle failure probability = $(ax+r)/(x+n)$	Pf = 0.25
	a = 0.25
Parameters used in vehicle failure probability computation	x = 4
	r = 0
	n = 0
Powered flight time - 1/2 each stage (sec)	tp = 400
Total start-up failure prob. (both stages)	Psu = 0.01425
Average failure rate (failures/sec)	fr = 0.0005894

The tables on the following page provide parametrically

- (1) the impact probability of an intact empty second stage and payload (flight aborted, but the vehicle not broken up and not containing propellant at impact), and
- (2) the risk to a single person on the Asset.

If we assume that:

- the cross-range uncertainty of the IIP of the second stage and payload is 8 km
- the IIP rate is 2 km/sec,
- the offset of the IIP from the asset is 12 km,

then the impact probability of the stage and payload on the Asset (from the tables) is 6×10^{-8} .

¹⁹ The IIP is assumed to be based on drag corrected impacts of the intact stage and payload.

If we want to find the cross-range position of the locus of IIP that produces a $P_1 = 1 \times 10^{-7}$, interpolate the values in the table, giving a result of approximately 8.8 km cross range. If the Asset is to be protected at a level of $P_1 = 1 \times 10^{-7}$ plus an additional 10 km, then the offset must be 18.8 km.

The comments about explosive or aerodynamic break up of the stage discussed in the previous section apply here. Having many pieces instead of one will raise the impact probability. However, the individual effect of a single fragment will be much less than the effect of the entire stage and payload.

This entire process can be applied to many populations centres, not just one. The best approach is to first determine the total population of an area of concern. Then subtract the total population of all of the identified communities from the total population of the area at risk to determine the population in the countryside. The countryside can then be divided into large areas with very low populations, with each area being treated as a population centre. The casualty area for these population centres does not need to take into account fragment dimensions to compute impact probability, the contribution is too small.

Table A2-7. P_1 and E_C Using Corridor Model for Various IIP Rates, Cross-Range Standard Deviations and Offsets of an Asset from the Nominal Locus of the IIP.

Cross Range Standard Deviation of Locus of IIP (km) =2							
Offset of Asset from Nominal IIP (yc) – km		IIP Rate (IIPR) - km/sec					
		1		2		5	
		PI	Ec/pers	PI	Ec/pers	PI	Ec/pers
20	0	1.5E-06	2.4E-08	7.4E-07	1.2E-08	3.0E-07	4.7E-09
	4	2.0E-07	3.2E-09	1.0E-07	1.6E-09	4.0E-08	6.4E-10
	8	5.0E-10	8.0E-12	2.5E-10	4.0E-12	9.9E-11	1.6E-12
	12	2.3E-14	3.6E-16	1.1E-14	1.8E-16	4.5E-15	7.3E-17
	16	2.2E-20	3.4E-22	1.1E-20	1.7E-22	4.3E-21	6.9E-23
	20	0.0E+00	0.0E+00	0.0E+00	0.0E+00	0.0E+00	0.0E+00

Cross Range Standard Deviation of Locus of IIP (km) =4							
Offset of Asset from Nominal IIP (yc) – km		IIP Rate (IIPR) - km/sec					
		1		2		5	
		PI	Ec/pers	PI	Ec/pers	PI	Ec/pers
20	0	7.4E-07	1.2E-08	3.7E-07	5.9E-09	1.5E-07	2.4E-09
	4	4.5E-07	7.2E-09	2.2E-07	3.6E-09	9.0E-08	1.4E-09
	8	1.0E-07	1.6E-09	5.0E-08	8.0E-10	2.0E-08	3.2E-10
	12	8.2E-09	1.3E-10	4.1E-09	6.6E-11	1.6E-09	2.6E-11
	16	2.5E-10	4.0E-12	1.2E-10	2.0E-12	5.0E-11	7.9E-13
	20	2.8E-12	4.4E-14	1.4E-12	2.2E-14	5.5E-13	8.8E-15

Cross Range Standard Deviation of Locus of IIP (km) =8							
Offset of Asset from Nominal IIP (yc) – km		IIP Rate (IIPR) - km/sec					
		1		2		5	
		PI	Ec/pers	PI	Ec/pers	PI	Ec/pers
20	0	3.7E-07	5.9E-09	1.8E-07	3.0E-09	7.4E-08	1.2E-09
	4	3.3E-07	5.2E-09	1.6E-07	2.6E-09	6.5E-08	1.0E-09
	8	2.2E-07	3.6E-09	1.1E-07	1.8E-09	4.5E-08	7.2E-10
	12	1.2E-07	1.9E-09	6.0E-08	9.6E-10	2.4E-08	3.8E-10
	16	5.0E-08	8.0E-10	2.5E-08	4.0E-10	1.0E-08	1.6E-10
	20	1.6E-08	2.6E-10	8.1E-09	1.3E-10	3.2E-09	5.2E-11

Other Considerations

If the vehicle impacts intact, the cross-range dispersions are primarily due to normal guidance and performance variations, wind dispersions and possibly dispersion due to a malfunction turn. The problem gets much more complicated if the vehicle breaks up. The many pieces of debris will vary in size and ballistic coefficient; they will have different velocity impulses due to any explosion; and they will all be affected by any vehicle malfunction turn. The more effective way of doing this analysis is to divide up the debris into categories that have commonality in ballistic coefficient and velocity impulse for each category. Then compute a drag corrected IIP for each of the different categories. These drag corrected IIPs will have different arrival times and may be offset from one another because of wind and earth rotation effects. The risk analysis is then performed for each debris category, for all population centres, and then summed.